

Stollmann E + V GmbH	TA+USBA Hardware reference
-------------------------	-------------------------------



TA+USBA

Hardware reference



Stollmann E + V GmbH	TA+USBA Hardware reference
-------------------------	-------------------------------



Note

This device was developed for the purpose of communication in an office environment. It is intended solely for our industrial clients for physical integration into their own technical products after careful examination by experienced technical personnel for its suitability for the intended purpose. The device was not developed for or intended for use in any specific customer application. The firmware of the device may have to be adapted to the specific intended modalities of use or even replaced by other firmware in order to ensure flawless function in the respective areas of application. Performance data (range, power requirements, etc.) may depend on the operating environment, the area of application, the configuration, and method of control, as well as on other conditions of use; these may deviate from the technical specifications, the Design Guide specifications, or other product documentation. The actual performance characteristics can be determined only by measurements subsequent to integration. Variations in the performance data of mass-produced devices may occur due to individual differences between such devices. Device samples were tested in a reference environment for compliance with the legal requirements applicable to the reference environment. No representation is made regarding the compliance with legal, regulatory, or other requirements in other environments. No representation can be made and no warranty can be assumed regarding the suitability of the device for a specific purpose as defined by our customers. Stollmann reserves the right to make changes to the hardware or firmware or to the specifications without prior notice or to replace the device with a successor model. Of course, any changes to the hardware or firmware of any devices for which we have entered into a supply agreement with our customers will be made only if, and only to the extent that, such changes can reasonably be expected to be acceptable to our customers. No general commitment will be made regarding periods of availability; these must be subject to individual agreement. All agreements are subject to our Terms and Conditions for Deliveries and Payments, a copy of which is available from Stollmann.

Copyright © 2005-2006 Stollmann E+V GmbH

Trademarks

Trademarks and trade names are those of their respective owners.

Author: aa	Date of Saving: 21.06.07	Ref: TA+USBA_HWreference_V1_00.doc	Revision:1.00	Page 2 of 14
------------	--------------------------	------------------------------------	---------------	--------------

Table of contents

1	Introduction	4
1.1	Feature Summary	4
1.2	Applications	4
2	Block Diagram	5
3	Application Interface	5
3.1	ISDN-Interface	5
3.2	USB-Interface	6
3.3	LED displays TA+USBA.....	7
3.3.1	List of LED States	8
4	Electrical Characteristics.....	9
4.1	Absolute Maximum Ratings	9
4.2	Electrical Requirements	9
4.3	Environmental Requirements.....	9
5	Mechanical Characteristics	10
5.1	Dimensions	10
5.2	TA+USB USB-interface connector	10
5.3	TA+USBA Pinout of the ISDN connector.....	11
6	Safety Guidelines.....	11
7	Regulatory Information.....	11
7.1	Declaration of CE conformity	11
7.2	RoHS Declaration	12
8	Related Documents	12
9	Ordering Information	12
10	Life Support Policy.....	13
11	History	14

1 Introduction

This Hardware Reference Guide documents how TA+USBA can be integrated into customer systems. It addresses developers of hardware environments for TA+USBA. For detailed information about software interfaces and AT-Commands refer to the software reference manual.

1.1 Feature Summary

- ISDN Layer 1: I.430/S0
- Signaling: DSS1
- Communication B-Channel: V.110, V.120, X.75, HDLC, transparent, PPP, ML-PPP, X.25
- Communication D-Channel: X.25, X.31
- USB 2.0 / 1.1 Slave
- Device Class: Communication
- Update and Configuration via USB or ISDN
- Powered from USB (optional Mains Power Supply)
- Dimensions 87,5 x 127 x 27mm
- Conformity CE
- Manufactured in conformance with RoHS

1.2 Applications

The TA+USBA connects devices with USB-Host- Accesses to ISDN. Embedded Devices can also connected because no ISDN specific Drivers are necessary. Host OS specific drivers for WINDOWS are supported. Additional drivers are supported on request.

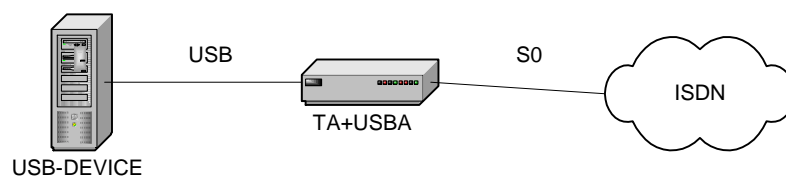

The TA+USBA includes the complete ISDN-Protocol for B- and D-Channel Communication, an AT-Handler and routes serial Data from USB Port to the ISDN-Network. The TA+USBA is compatible to all ISDN-PABX, serial Terminals and PC-Cards.

2 Block Diagram

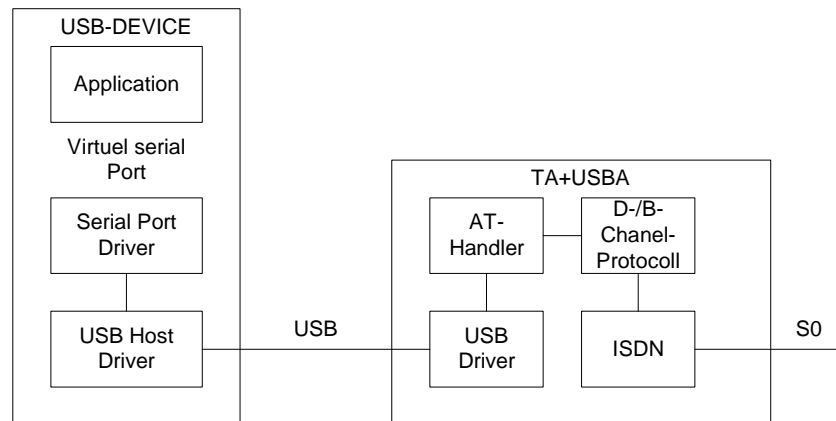

Figure 2.1 TA+USBA block diagram

3 Application Interface

3.1 ISDN-Interface

This Interface operates physically in ISDN Layer 1: S0(BRI)/I.430 Standard

The ISDN D-Channel Protocol to the ISDN Line could be

- DSS1 (Euro-ISDN) or 1TR6 (german national protocol)
- Leased line (64S)

The B-Channel Protocol includes following Transmission Protocols

- V.110 asynchronous
- HDLC async. to sync. conversion (PPP asynchronous)
- HDLC transparent (octets are packed into HDLC frames)
- Byte transparent voice connection (raw B channel data)
- X.75 SLP
- V.120 async.
- X.31 B-Channel (X.25 B-Channel)

Stollmann E + V GmbH	TA+USBA Hardware reference
-------------------------	-------------------------------



- X.31 D-Channel
- T.70NL
- T.90NL
- MLPPP

3.2 USB-Interface

The TA+USBA USB-Interface operates in Slave-Mode regarding to the Standard USB2.0 / 1.1.

The Data-Rate on the USB-Port is min. 300bit/s up to max. 230400bit/s. Flow Control can be RTS / CTS or none.

At the back of the TA+USBA you will find the connectors for the following devices:

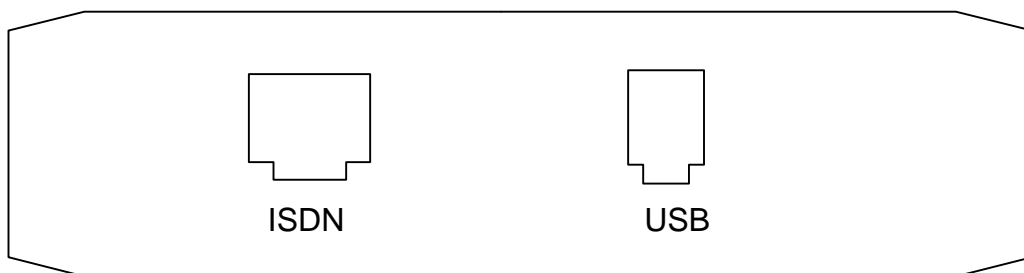

Figure 3.1 Back view of the desktop model TA+USBA

ISDN: S0 ISDN-Interface
USB: USB-Interface for DTE, i.e. a PC

3.3 LED displays TA+USBA

You can control the status of the TA+USBA via 8 LEDs at the front side.

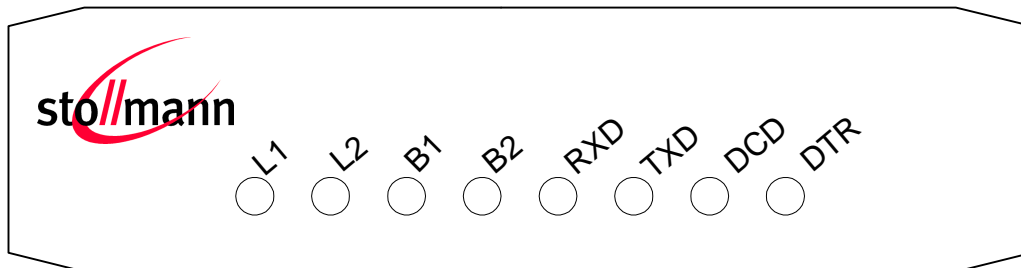

Figure 3.2 Front view of the desktop model TA+USBA

The 4 LEDs at the right show the status of the serial interface to the PC:

- RXD** : shows activity of receiving data from the ISDN line
- TXD** : shows activity of transmitted data from the terminal
- DCD** : represents the status of the DCD line (V.24);
indicated normally a ISDN data connection.
- DTR** : shows the status of DTR line, i.e. the terminal is trying to connect via
the TA+USBA.

Both LEDs, **B1** and **B2**, show the connection state of the ISDN B channels:
If ON this B channel is occupied due to an incoming or outgoing connection.

Both of the LEDs, **L1** and **L2**, show the overall status of the TA+USBA in coded
form. The following list describes the view for an error free power on sequence of
the TA+USBA.

	Status	Time	L1	L2	B1	B2
1.	Power-On-Phase, wait	1 second	O	O	O	O
	Power-On-Phase, wait	0,3 seconds	⊗	⊗	⊗	⊗
	Power-On-Phase, wait	5 second	O	O	O	O
2.	Active phase, ISDN ok		⊗	O	O	O
3.	Connected, ISDN data connection on B1 channel		⊗	⊗	⊗	O
	Connected, ISDN data connection on B2 channel		⊗	⊗	O	⊗

LED Legend:

⊗	On
⊕	Continuously blinking
○	Off

3.3.1 List of LED States

Active states:

L1	L2	Status
⊕ (1x1s)	○	ISDN not ok ; Check ISDN interface/ -connector
⊗	○	Active phase ; ISDN ok, no ISDN connection
⊗	∅	Call active ; ISDN Connection will be established
⊗	⊕	Synch active ; Waiting for B channel synchronization
⊗	⊗	Connected ; Data connection is established

B1	B2	Status B channels
○	○	B channel offline ;
⊗	○	B1 channel online; ISDN connection established
○	⊗	B2 channel online; ISDN connection established
⊕	⊕	B1, B2 flashing: Bootloader active, no operational firm-ware programmed. Use command at**flash to download firmware with 115200 Bd,N81.

Error states:

L1	L2	Status
○	○	TA+USBA not ok ; Hardware error ; TA+USBA repair necessary
⊕	○	ISDN not ok ; Check ISDN interface/ -connector
○	⊕ (nx1s)	TA+USBA not ok ; Hardware error, ; TA+USBA repair necessary
⊕	⊕	L1, L2 flashing: Bootloader active, no operational firm-ware programmed. Use command at**flash to download firmware with 115200 Bd,N81.

4 Electrical Characteristics

4.1 Absolute Maximum Ratings

Stresses beyond those listed under “Absolute Maximum Ratings” may cause permanent damage to the device. These are stress ratings only, and functional operation of the device at these or any other conditions beyond those indicated under “Electrical Requirements” is not implied. Exposure to absolute-maximum-rated conditions for extended periods may affect device reliability.

Item	Symbol	Absolute Maximum Ratings	Unit
Supply voltage	V_{USB}	-0.4 to +5,25	V
Supply voltage *1)	$V_{ext.}$	-0.4 to +5,25	V

*) Optional Power Supply on request

4.2 Electrical Requirements

$V_{USB} = 5V$, $T_{amb} = 25^{\circ}C$ if nothing else stated

Item	Condition	Limit			Unit
		Min	Typ	Max	
V_{USB}		4,8	5	5.25	V
I _{USB close}	COM-port closed	24	28	32	mA
I _{USB standby}	Standby	28	34	40	mA
I _{USB comm.}	Communication / 2 B-Channels	69	75	81	mA
I _{USB fd.}	Firmware Download	54	62	70	mA

4.3 Environmental Requirements

Item	Sym- bol	Absolute Maximum Ratings	Unit
Storage temperature range	T_{stg}	-20 to +80	$^{\circ}C$
Operating temperature range	T_{op}	0 to +70	$^{\circ}C$
Humidity	%	80, non-condensing	rF

5 Mechanical Characteristics

5.1 Dimensions

87,5 x 127 x27mm

5.2 TA+USB USB-interface connector

Pinout of the 4 pin USB-interface Type B

Pin	Signal (S bus)
1	USB+ (PowerSupply)
2	DM (Data)
3	DP (Data)
4	USB- (Ground)

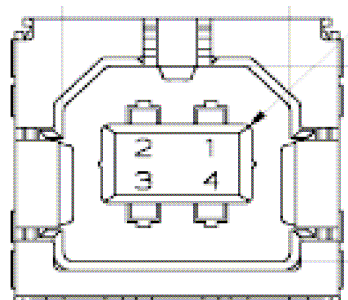

Figure 5.1 Front view of the USB-interface Type B

5.3 TA+USBA Pinout of the ISDN connector

Pinout of the 8 pin ISDN S-interface connector (RJ45) (ITU I.430/ISO 8877)

Pin	Signal (S bus)
1	Not connected
2	Not connected
3	Tx+ (Transmit +)
4	Rx+ (Receive +)
5	Rx- (Receive -)
6	Tx- (Transmit -)
7	Not connected
8	Not connected

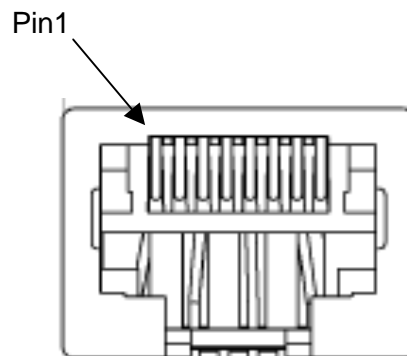

Figure 5.2 Front view of the 8 pin ISDN S-interface connector (RJ45)

6 Safety Guidelines

7 Regulatory Information

7.1 Declaration of CE conformity

EMC: EN55022 (2003-09), EN55024 (2003-10) - pending

Safety: EN60950 (2006-11) - pending

R&TTE: CTR3/A1 - pending

Stollmann E + V GmbH	TA+USBA Hardware reference
-------------------------	-------------------------------



7.2 RoHS Declaration

Declaration of environmental compatibility for supplied products:

Hereby we declare to our best present knowledge based on declaration of our suppliers that this product do not contain by now the following substances which are banned by Directive 2002/95/EC (RoHS) or if contain a maximum concentration of 0,1% by weight in homogeneous materials for

Lead and lead compounds

Mercury and mercury compounds

Chromium (VI)

PBB (polybrominated biphenyl) category

PBDE (polybrominated biphenyl ether) category

And a maximum concentration of 0,01% by weight in homogeneous materials for

Cadmium and cadmium compounds

8 Related Documents

[1] [Stollmann: TA+USBA_TechnicalOverview_V1_01_en.pdf](#)

[2] [Stollmann: TA+USBA_command_reference_V1_00_en.pdf](#)

[3] [Stollmann: TA+USBA_usage_guide_V1_00.pdf](#)

9 Ordering Information

TA+USBA is available in the following variants:

Name		Article No.
TA+USBA		52738

Author: aa	Date of Saving: 21.06.07	Ref: TA+USBA_HWreference_V1_00.doc	Revision:1.00	Page 12 of 14
------------	--------------------------	------------------------------------	---------------	---------------

Stollmann E + V GmbH	TA+USBA Hardware reference
-------------------------	-------------------------------



10 Life Support Policy

This Stollmann product is not designed for use in life support appliances, devices, or systems where malfunction can reasonably be expected to result in a significant personal injury to the user, or as a critical component in any life support device or system whose failure to perform can be reasonably expected to cause the failure of the life support device or system, or to affect its safety or effectiveness. Stollmann customers using or selling these products for use in such applications do so at their own risk and agree to fully indemnify Stollmann for any damages resulting.

Author: aa	Date of Saving: 21.06.07	Ref: TA+USBA_HWreference_V1_00.doc	Revision:1.00	Page 13 of 14
------------	--------------------------	------------------------------------	---------------	---------------

Stollmann E + V GmbH	TA+USBA Hardware reference
-------------------------	-------------------------------



11 History

Version	Release Date	By	Change description
0.10	12.02.2007	AA	Start
1.00	23..02.2007	BS/ AA	Updated