



TA+P2I

Adapting ISDN Phones to
POTS FXS

User Manual

Release r06

Note

This device was developed for the purpose of communication in an office environment. It is intended solely for our industrial clients for physical integration into their own technical products after careful examination by experienced technical personnel for its suitability for the intended purpose. The device was not developed for or intended for use in any specific customer application. The firmware of the device may have to be adapted to the specific intended modalities of use or even replaced by other firmware in order to ensure flawless function in the respective areas of application. Performance data (range, power requirements, etc.) may depend on the operating environment, the area of application, the configuration, and method of control, as well as on other conditions of use; these may deviate from the technical specifications, the Design Guide specifications, or other product documentation. The actual performance characteristics can be determined only by measurements subsequent to integration. Variations in the performance data of mass-produced devices may occur due to individual differences between such devices. Device samples were tested in a reference environment for compliance with the legal requirements applicable to the reference environment. No representation is made regarding the compliance with legal, regulatory, or other requirements in other environments. No representation can be made and no warranty can be assumed regarding the suitability of the device for a specific purpose as defined by our customers. Stollmann reserves the right to make changes to the hardware or firmware or to the specifications without prior notice or to replace the device with a successor model. Of course, any changes to the hardware or firmware of any devices for which we have entered into a supply agreement with our customers will be made only if, and only to the extent that, such changes can reasonably be expected to be acceptable to our customers. No general commitment will be made regarding periods of availability; these must be subject to individual agreement. All agreements are subject to our Terms and Conditions for Deliveries and Payments, a copy of which is available from Stollmann.

Copyright © 2005-2008 Stollmann E+V GmbH

Trademarks

The Bluetooth® word mark and logos are owned by the Bluetooth SIG, Inc. and any use of such marks by Stollmann E+V GmbH is under license. Other trademarks and trade names are those of their respective owners.

Table of contents

1	Introduction.....	4
1.1	Product description	4
2	Installation	5
2.1	Content.....	5
2.2	Procedure of Installation for ISDN phones	5
2.3	Procedure of Installation for ISDN PABX	7
2.4	Displays.....	8
2.5	Interfaces.....	9
3	Usage of the TA+P2I	9
3.1	Incoming call.....	10
3.2	Outgoing call.....	11
3.3	Call waiting	11
3.4	Call Hold / Enquiry	11
3.5	Three party conference.....	12
3.6	Call forwarding.....	12
3.7	Additional supplementary services.....	12
4	Error Diagnostic.....	13
4.1	Error: Phone calls not possible	13
4.2	Error: No dial tone.....	14
4.3	Error: No incoming calls.....	14
4.4	FAQ.....	14
5	Configuration	15
5.1	Overview configuration commands	15
6	Operation Mode.....	15
7	Technical features	16
7.1	Analogue ports	16
7.2	ISDN ports.....	16
8	History	18

1 Introduction

We are very pleased to see that you have purchased a Stollmann product and would like to express our appreciation.

This documentation is valid for the product TA+P2I:

- Software version V1.715 or later

1.1 Product description

Using the TA+P2I you can connect ISDN phones or an ISDN PABX with two analogue interfaces (POTS FXS).

The analogue lines of the TA+P2I react like standard analogue phones und have to be connected with the FXO ports of the switching system or adapter.

The ISDN interface has identical function equal to an ISDN interface presented by an NT1 or a PABX.

You can connect up to 8 ISDN phones to the ISDN interface whereas up to 4 ISDN phones can be powered by the TA+P2I.

ISDN modems for data transmission and ISDN fax machine group 4 cannot be driven by the TA+P2I.

Devices based on voice connection like answering machines and fax G3 machines are supported.

2 Installation

2.1 Content

This package contains the following parts:

- TA+P2I adapter
- External power supply (cable length approx. 1.85m)
- Two cable for the analogue interfaces (cable length approx. 1.00m)
- This user manual
- Quick installation guide

2.2 Procedure of Installation for ISDN phones

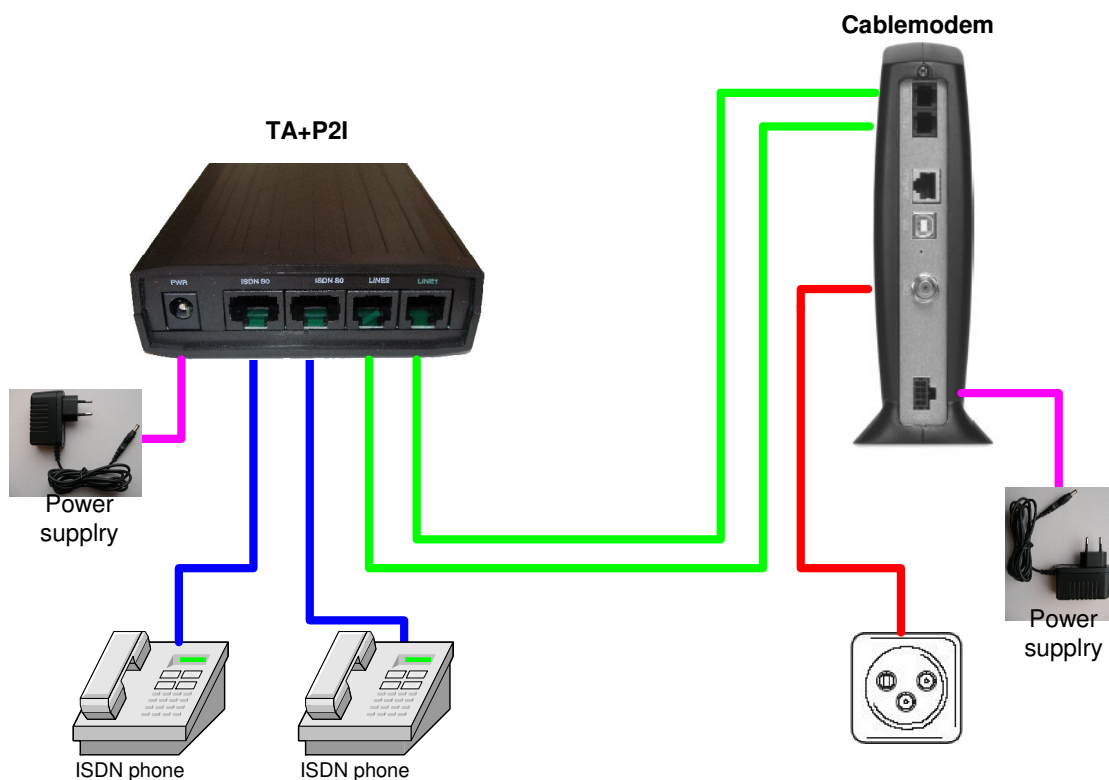

The installation of your TA+P2I is done in a few simple steps:

- Connect the power supply to the TA+P2I and mains: The green LED "READY" at the front panel will be lit.
Attention: Please use only the delivered power supply!
- Connect „LINE 1“ with the first analogue line of the cable modem, LINE 2 with the second one. The corresponding LEDs LINE1 and LINE2 will be lit green.
- Connect the ISDN phone(s) to one or both ISDN plugs. As an alternative you can connect the previous installed ISDN cabling to one of the ISDN plugs.

Note: The ISDN terminating resistors for the ISDN network are integrated inside the TA+P2I already.

- Check whether you can receive calls using all called numbers. If you have problems please proceed as follows:
 - If one ISDN phone shall react on all incoming calls from both lines it is necessary to delete all still activated MSN settings inside the ISDN phone.
 - If one ISDN phone shall react only to the phone numbers of one of the analogue lines of the cable modem, change the former MSN settings and use the digit "1" as MSN for that phone, which shall react on incoming call from line 1. Please handle the same way for the ISDN phone that shall be allocated to line 2, this phone needs the digit "2" as MSN setting.
 - Example:
 - For line 1 was associated the call number 123123123 and for line 2 the call number 456456456
 - If an ISDN phone shall only accept incoming calls for the number 123123123, set up the MSN of this phone to „1“.
 - If another phone shall react on incoming calls to 456456456, set up the MSN of this phone to „2“.
 - If a third phone shall react on all incoming calls, so delete all MSNs of that phone.
- More information you can find in your phone manual. If you have problems setting up MSNs please contact your dealer or the manufacturer of the phone.

More setups you will find in the next chapter.

2.3 Procedure of Installation for ISDN PABX

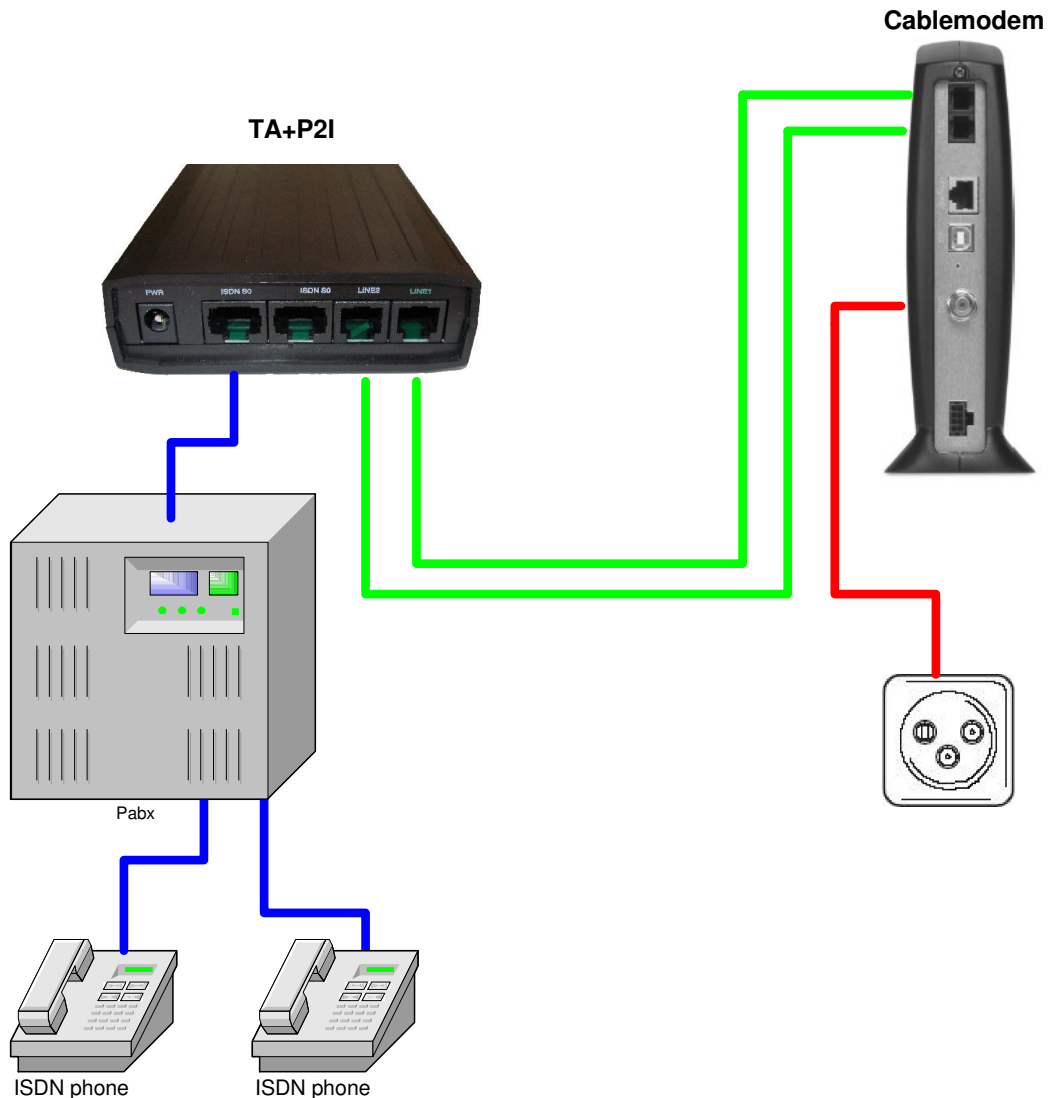

To use the TA+P2I with an ISDN PABX please do the steps below:

- Connect the power supply to the TA+P2I and mains: The green LED “READY” at the front panel will be lit permanently.

Attention: Please use only the delivered power supply!

- Connect “LINE 1” with the first analogue line, “LINE 2” with the second one. The corresponding LEDs LINE1 and LINE2 will be lit green.
- Connect the public line port of the PABX to one ISDN plug.

Note: The ISDN terminating resistors for the ISDN network are integrated inside the TA+P2I already.

- For accepting incoming calls with the correct calling number, you have to set up the MSN inside the ISDN PABX:
Set up the MSN of your ISDN PABX as they are signaled by the TA+P2I:
By default the MSN "1" for the analogue line 1 and the MSN "2" for the analogue line 2.

2.4 Displays



READY	The TA+P2I is powered and ready to use
ERROR	Hardware error, the TA+P2I cannot be used
LINE1	<i>Lit:</i> The analogue line 1 is connected to a working analogue interface <i>Blinking:</i> The analogue line 1 is connected to a working analogue interface, but there is no dial tone
LINE2	<i>Lit:</i> The analogue line 2 is connected to a working analogue interface <i>Blinking:</i> The analogue line 2 is connected to a working analogue interface, but there is no dial tone
ISDN1	The first B channel is in use respectively the hand set of the ISDN phone is off hook
ISDN2	The second B channel is in use respectively the hand set of the ISDN phone is off hook
CONF	The configuration of the TA+P2I has been changed
EXT	Reserved

2.5 Interfaces

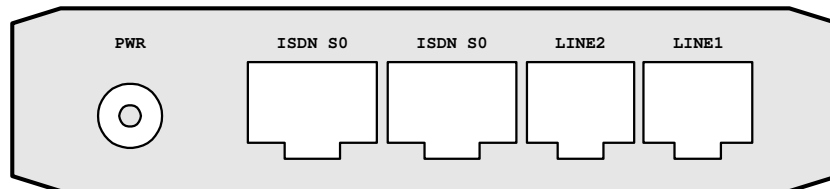

LINE1	Interface for the first analogue line
LINE2	Interface for the second analogue line
ISDN S0	First plug for ISDN devices
ISDN S0	Second plug for ISDN devices
PWR	Interface for external power supply

! Attention: Please use only the delivered power supply !

3 Usage of the TA+P2I

By adapting with the TA+P2I you can use many supplementary services known from the ISDN also via the analogue lines, the services have to be activated on the analogue lines.

The TA+P2I supports the following supplementary services:

- Outgoing call including transmission of calling party number
- Calling line identification restriction
- Incoming call including display of calling party
- Call waiting
- Call hold
- Three party conference (3PTY)
- Barring incoming calls
- Terminal portability (TP)
- Call forwarding (CFU, CFB, CFNR)

More services may be available depending on the characteristics of the analogue lines, these can be driven from the ISDN phone transparently by key inputs.

3.1 Incoming call

An incoming call will be shown via the ringing tone and the calling number display as if the ISDN phone would be connected to the ISDN network directly.

To route the incoming calls to the addressed ISDN phones it is necessary to set up the MSN of each ISDN phone. If the MSN is not configured (MSN = <empty>) in the ISDN phone, the ISDN phone is ringing on incoming calls both on analogue line 1 and analogue line 2.

If a wrong MSN (a MSN which does not match with any MSN configured in the TA+P2I) is configured in the ISDN phone, the ISDN phone is not ringing.

By factory the associated MSNs for the two analogue line are set to 1 (line1) and 2 (line2). For using the factory setting set up the MSN of your phones accordingly:

Phone with MSN = 1 is ringing on incoming calls on analogue line 1.

Phone with MSN = 2 is ringing on incoming calls on analogue line 2.

For experts only:

If a phone number according to the call number of the analogue lines shall be used, you have to set up this correct MSN both in the TA+P2I and the ISDN phones.

To change the setting for the MSN for analogue line 1 please do the following:

- Please enter the following number in on hook state of the ISDN phone
- **00000101xxx** = Set the first MSN for analogue line 1 to xxx (factory default 1: „Dialing 000001011“)
- Go off hook
- Go on hook

Please proceed adequate for the second analogue line, please dial instead:

00000102xxx = Set the first MSN for analogue line 2 to xxx (factory default 2: „Dialing 000001022“).

Two additional MSNs can be programmed for each line accordingly by using other dial codes (see chapter configuration).

Note: The settings can only be changed by using an ISDN phone directly connected to the TA+P2I. Changing the settings via a ISDN PABX are not possible, because the configuration command is not transmitted to the TA+P2I.

3.2 Outgoing call

An outgoing call will be started identical as if the ISDN phone would be connected directly to the ISDN network via the menu and the keys of the ISDN phone.

The MSNs entered in the ISDN phone and the TA+P2I define the analogue interface (line 1 or line 2), that will be used for the outgoing call. If no MSN is defined in the ISDN phone, the TA+P2I uses the next free analogue line (line 1 or line 2). If a wrong MSN (a MSN which does not match with any MSN configured in the TA+P2I) is configured in the ISDN phone, an outgoing call is not possible.

In case that during an outgoing call an assumed call pause of approx. 10 seconds occur, this can be reduced to approx. 5 seconds by terminating the call attempt with the # key.

Background: The assumed call pause is caused by the analogue interface (DTMF tones are not hearable via ISDN) and the cable modem. The cable modem establishes the voice connection via VoIP.

An example of an outgoing call attempt using the # key looks like follows:

<phone number># (i.e. 123456789#)

Important: Some ISDN phones do not support (or it is disabled by default) dialing using # key in the dial string. Please refer to the user manual of your ISDN phone to change this setting.

To make an outgoing call with calling line restriction please use the menu user interface of the ISDN phone. The signaling sequence will be adapted automatically by the TA+P2I.

Note: The ISDN phone can display „connected“ although the connection has not been established completely. This behavior is caused by the technology.

3.3 Call waiting

Call waiting will be signaled as if connected to an ISDN network. The display text and tone signaled is dependent on the configuration of the ISDN phone and will be shown according to the ISDN phone features and settings (typical by an acoustic tone and a display entry).

3.4 Call Hold / Enquiry

You can start an enquiry by the typical sequence as usual for the ISDN phone (menu key or R key).

3.5 Three party conference

You can start a three party conference by the typical sequence as usual for the ISDN phone (menu driven).

3.6 Call forwarding

You can activate and deactivate call forwarding by the typical sequence as usual for an analogue line by prefix codes. These codes are predefined by your service provider.

Activation and deactivation is only possible by using the appropriate keys of the ISDN phone (i.e. *21<phone number>). Activation and deactivation by using the menu keys of an ISDN phone or an ISDN PABX is not possible.

3.7 Additional supplementary services

Additional services like call completion to busy subscriber, call transfer, etc. are not available via the menu driven interface of the ISDN phone. These services are defined by the services of the analogue lines and are controlled by keypad input (DTMF tones). The display information of the ISDN phone is also not available.

Please refer to the services supported by your provider of the analogue lines.

4 Error Diagnostic

4.1 Error: Phone calls not possible

Is the READY LED lit green?	If not, please check, whether the delivered power supply is adapted correctly. Disconnect the power supply for several seconds. Is the READY LED still off or is the ERROR LED lit, the device has a hardware error. Please contact your supplier.
Is the LINE1 LED lit green?	If not, please check the connection between the plug LINE1 and the analogue port.
Is the LINE1 LED blinking green?	The analogue line 1 is connected to a working analogue interface, but there is no dial tone.
Is the LINE2 LED lit green?	If not, please check the connection between the plug LINE2 and the analogue port.
Is the LINE2 LED blinking green?	The analogue line 2 is connected to a working analogue interface, but there is no dial tone.
Is the MSN programmed in the ISDN phone also programmed in the TA+P2I?	Check the setting of the MSNs in the ISDN phone and the TA+P2I. In the default configuration of the TA+P2I MSN "1" is configured for analogue line 1 and MSN "2" is configured for analogue line 2. Please check if the ISDN phone is configured accordingly (i.e. MSN-A = 1).

4.2 Error: No dial tone

ISDN1 or ISDN2 lit, but there is no dial tone.

- A The analogue line is connected to a working analogue interface, but there is no dial tone. Please check in the customer portal of Kabel Deutschland if a phone number is activated at the analogue line.
- B Another phone already uses the same analogue line. Check if a busy tone can be heard and/or the phone display indicates that the line is busy.

4.3 Error: No incoming calls

Is the setting of the MSN correct?

Check the setting of the MSN in the ISDN phone and the TA+P2I. Please refer additionally to chapter incoming call.

4.4 FAQ

- The TA+P2I supports all ISDN phones and ISDN PABX's configured to "multipoint" mode.
- The TA+P2I does not support data connections via ISDN modems or ISDN PC cards. Voice connections like answering machine and fax G3 are supported.
- Call waiting: Due to technical reason another phone in the same phone number group is ringing in case of call waiting. But it is not possible to accept the waiting call with this phone, only the active phone may accept the waiting call.
- For additionally frequently asked questions please refer to our web site:
<http://www.stollmann.de>

5 Configuration

5.1 Overview configuration commands

Each configuration command has to be dialed en-bloc from the ISDN phone. Enter the configuration dial number, go off hook and go on hook.

00000101xxx	Set-up first MSN xxx for line 1
00000111xxx	Set-up second MSN xxx for line 1
00000121xxx	Set-up third MSN xxx for line 1
00000102xxx	Set-up first MSN xxx for line 2
00000112xxx	Set-up second MSN xxx for line 2
00000122xxx	Set-up third MSN xxx for line 2

(The MSN xxx may consist of 1...20 digits)

000002011	Barring incoming calls for line 1
000002021	Barring incoming calls for line 2
000002010	Release barring of incoming calls for line 1
000002020	Release barring of incoming calls for line 2

00000103ddmmyyhhmm Set-up date and time

00000104yy Set-up year only

(dd=day; mm=month; yy=year; hh=hour; mm=minute)

00000980 Reset all parameters to factory default

6 Operation Mode

The TA+P2I can only be used in „multipoint“ operation mode.

7 Technical features

Function	TA+P2I
Power supply	External plug in power supply Input 100-240V AC Output 12V DC 1,25A
Dimensions	127 x 88 x 27 mm
CE conformity	CE Europe

7.1 Analogue ports

Function	TA+P2I
Plug	2 x RJ11
Ringing detection	20 to 50 Hz
Off-Hook / On-Hook signaling	√
DTMF dial	√
Barring incoming call	√
CLIP detection (FSK)	√
Busy tone detection	√

Pin assignment analogue plug (6 pin; RJ11)

Pin	Signal (a/b)
1	Not connected
2	Not connected
3	a (TIP)
4	b (RING)
5	Not connected
6	Not connected

7.2 ISDN ports

Function	TA+P2I
ISDN interface	1 x I.430 LT-S mode (S-Bus, BRI)
Plug	2 x RJ 45
Terminating resistors	Integrated, 2 x 100 Ohm
Phantom feeding ISDN-Bus	4 Watt
Supplementary services TA+P2I	MSN, DDI, call waiting, hold, resume, three party conference, call forwarding
Supplementary services transparent using DTMF	All available on analogue line
D channel protocol	DSS1 LT-S mode
Interfacing modes	Multipoint
B channel	G.711 a-law (analogue voice)
Configuration	Block dial via ISDN phone

Pin assignment ISDN plug (8 pin; RJ45; ITU I.430/ISO 8877)

Pin	Signal (S ₀)
1	Not connected
2	Not connected
3	[2a] Rx+ (Receive +)
4	[1a] Tx+ (Transmit +)
5	[1b] Tx- (Transmit -)
6	[2b] Rx- (Receive -)
7	Not connected
8	Not connected

8 History

Version	Release Date	By	Change description
r04	Nov 2007	is	First release for firmware version 1.701
r05	Mar 2008	nh	New document structure, Added pin assignment for analogue/ISDN plug Changes for new firmware version 1.715: - Modified behavior depending on the MSN settings during outgoing call - New parameter for setting the year - Modified LED behavior for LINE1, LINE2, ISDN1, ISDN2
r06	Jun 2008	ta	Revised chapter Call Forwarding

In case of technical problems or if you have questions about the installation please contact our **service hotline** under **01805 - 91 31 09**.

The service is available Monday - Sunday between 8:00 am and 12:00 pm.

(14ct/minute in German telephone network. Different costs may occur when calling from mobile phone.)