

BlueMod+B20/AI BlueMod+B20/AP BlueMod+B20/AP/L

Hardware Reference

Release r06

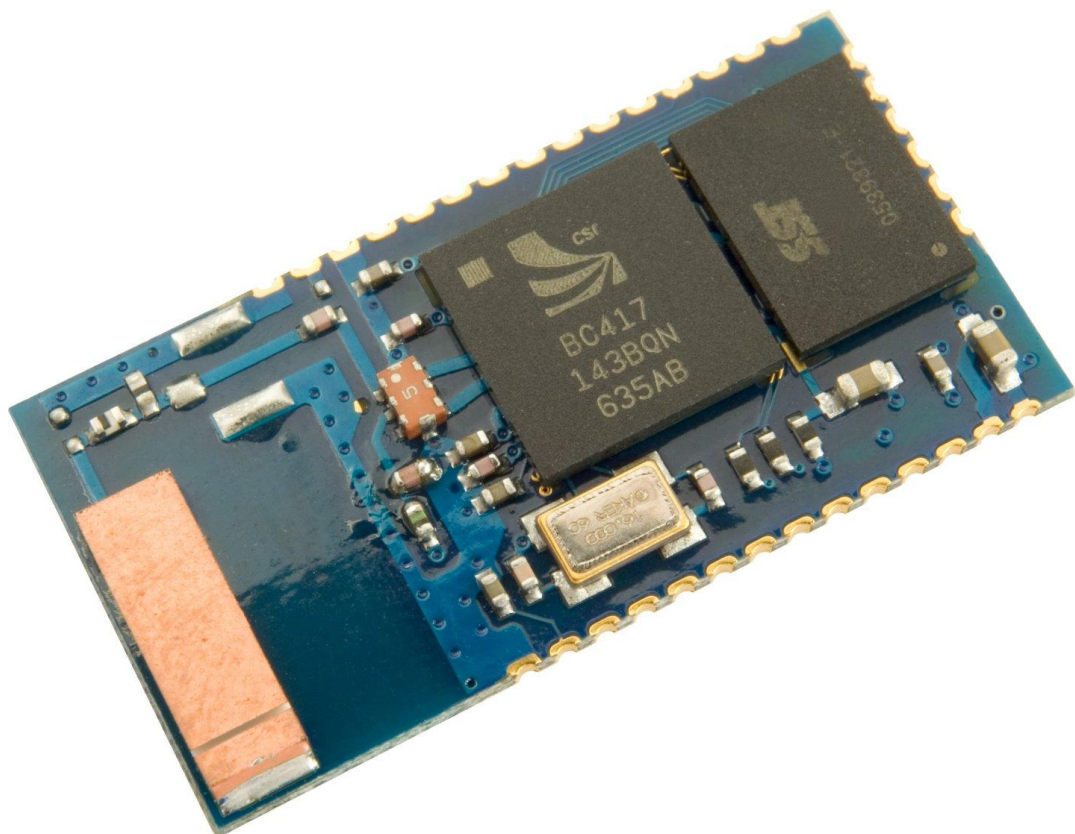

Note

This device was developed for the purpose of communication in an office environment. It is intended solely for our industrial clients for physical integration into their own technical products after careful examination by experienced technical personnel for its suitability for the intended purpose. The device was not developed for or intended for use in any specific customer application. The firmware of the device may have to be adapted to the specific intended modalities of use or even replaced by other firmware in order to ensure flawless function in the respective areas of application. Performance data (range, power requirements, etc.) may depend on the operating environment, the area of application, the configuration, and method of control, as well as on other conditions of use; these may deviate from the technical specifications, the Design Guide specifications, or other product documentation. The actual performance characteristics can be determined only by measurements subsequent to integration. Variations in the performance data of mass-produced devices may occur due to individual differences between such devices. Device samples were tested in a reference environment for compliance with the legal requirements applicable to the reference environment. No representation is made regarding the compliance with legal, regulatory, or other requirements in other environments. No representation can be made and no warranty can be assumed regarding the suitability of the device for a specific purpose as defined by our customers. Stollmann reserves the right to make changes to the hardware or firmware or to the specifications without prior notice or to replace the device with a successor model. Of course, any changes to the hardware or firmware of any devices for which we have entered into a supply agreement with our customers will be made only if, and only to the extent that, such changes can reasonably be expected to be acceptable to our customers. No general commitment will be made regarding periods of availability; these must be subject to individual agreement. All agreements are subject to our Terms and Conditions for Deliveries and Payments, a copy of which is available from Stollmann.

Copyright © 2005-2010 Stollmann E+V GmbH

Trademarks

The Bluetooth® word mark and logos are owned by the Bluetooth SIG, Inc. and any use of such marks by Stollmann E+V GmbH is under license. Other trademarks and trade names are those of their respective owners.

Table of contents

1	Introduction	5
1.1	Feature Summary	5
1.2	Applications	6
1.2.1	Cable Replacement, Serial Point-to-point.....	7
1.2.2	Cable Replacement, Multipoint	7
1.2.3	Terminal Server	8
1.2.4	PC Client.....	8
2	Block Diagram	9
3	Application Interface	10
3.1	Power Supply.....	10
3.2	Reset	11
3.2.1	UART Configuration in reset	11
3.3	Serial Interface.....	12
3.3.1	3-wire Serial Interface	12
3.3.2	Baudrate tolerance.....	12
3.4	PIO Interface.....	13
3.5	I ² C Interface.....	13
3.6	Bluetooth radio Interface	13
3.7	PCM Interface.....	14
3.8	USB Interface	15
3.8.1	D+, D-	15
3.8.2	USB Self-Powered Mode	15
3.8.3	USB Bus-Powered Mode	16
3.9	Serial Peripheral Interface.....	17
4	Pin Description	18
4.1	Pin Numbering	18
4.2	Pin Description.....	20
4.2.1	General Pin Description	20
4.2.2	Application Specific Pin Description	21

4.2.2.1	SPP Pin Configuration DCE Mode.....	21
4.2.2.2	SPP Pin Configuration DTE Mode.....	23
5	Electrical Characteristics.....	25
5.1	Absolute Maximum Ratings.....	25
5.2	Electrical Requirements.....	25
5.3	Environmental Requirements.....	25
5.4	Digital I/O including RESET#.....	26
5.5	AIO-Interface.....	26
5.6	USB-Interface.....	27
5.7	Power consumption and power down modes.....	27
5.7.1	HCI Configuration.....	27
5.7.2	SPP Configuration.....	27
5.8	RF performance.....	28
5.9	Power-up time.....	28
6	Mechanical Characteristics.....	29
6.1	Dimensions.....	29
6.2	Recommended Land Pattern.....	31
6.3	Re-flow Temperature-Time Profile.....	33
6.4	Restricted Area.....	34
6.5	Housing Guidelines.....	35
6.6	Antenna Issues.....	36
6.7	Safety Guidelines.....	39
7	Approvals/Certifications.....	40
7.1	Declaration of conformity.....	40
7.2	FCC Compliance.....	41
7.2.1	FCC Grant.....	41
7.2.2	FCC/IC Statement.....	42
7.2.3	Caution.....	42
7.2.4	FCC Warning.....	42
7.2.5	RF-exposure Statement.....	42

7.2.6	Labeling requirements for the End Product	43
7.3	Bluetooth Qualification	43
7.4	RoHS Declaration	46
8	Related Documents	46
9	Packing	47
9.1	Tape	47
9.2	Reel	47
10	Ordering Information.....	48
11	History.....	49

1 Introduction

This Hardware Reference documents how the BlueMod+B20/AI, BlueMod+B20/AP/L and BlueMod+B20/AP can be integrated into customer systems. It addresses hardware specifications of the BlueMod+B20/AI, BlueMod+B20/AP/L and /AP and requirements of the hardware environments for the BlueMod+B20/AI and BlueMod+B20/AP. Since Q3 2007 the BlueMod+B20/AI, BlueMod+B20/AP/L is available as industrial temperature range (/I) variant only.

For detailed information about software interfaces refer to [3], [4].

For the latest version of this document please check the following URL:

<http://www.stollmann.de/en/support/downloads/bluetooth-adapter/bluemod-b2x.html>

1.1 Feature Summary

- Bluetooth specification V2.0+EDR (**E**nhanced **D**ata **R**ate), or Bluetooth specification V2.1 compliant
- CSR BlueCore4-External inside
- Complete Co-location and Co-existence with 802.11 (AWMA, AFH and SFH)
- Fast Connection Setup
- RF output power class 2 with power control
- Supply Voltage 3.3V
- Internal crystal oscillator (26 MHz or 16 MHz)
- Surface mount type:
 - BlueMod+B20/AI: 14.5 x 28.0 x 2.7 mm

BlueMod+B20/AP: 14.5 x 20.0 x 2.0 mm

BlueMod+B20/AP/L: 14.5 x 28.0 x 2.7 mm

- Bluetooth enhanced data rate up to 2178kbps asymmetric
- Support for all Bluetooth power saving modes (Park, Sniff, Hold)
- μ -law, A-law and CVSD transcoders on SCO channel
- 13 or 16 bit linear, 8 bit μ -law or a-law PCM interface
- Full 8- to 128-bit encryption
- High sensitivity design (-81 dBm typ.)
- USB, UART and I²C interface
- 11 digital + 2 analog IO's for individual usage by embedded software
- 16bit RISC core for embedded profiles or application software
- Power control
- Manufactured in conformance with RoHS

1.2 Applications

The BlueMod+B20/AI, BlueMod+B20/AP/L and BlueMod+B20/AP can be used in different applications. Some typical applications are described in this chapter. For applications requiring an external adapter please refer to other BlueRS+ versions from Stollmann.

1.2.1 Cable Replacement, Serial Point-to-point

To establish a cable replacement connection between two devices with a serial interface, the BlueMod+B20/AI, BlueMod+B20/AP/L or BlueMod+B20/AP can be used.

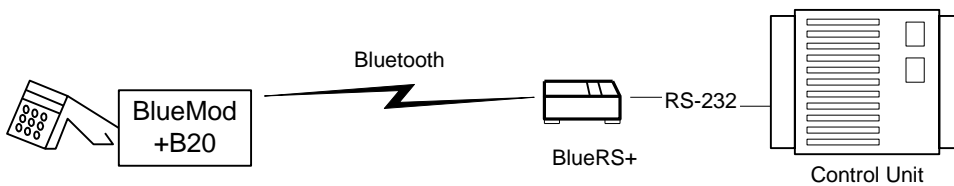

1.2.2 Cable Replacement, Multipoint

Since several devices may be connected with a master device via Bluetooth, several end devices can also be multiplexed via Bluetooth. This set up is shown below for a desktop device.

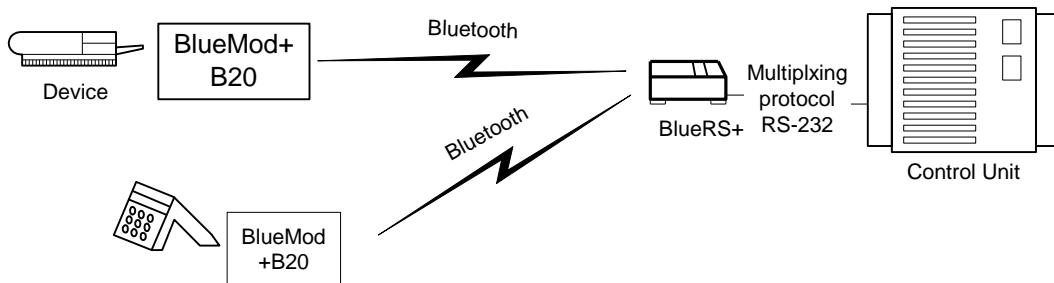

In order to handle multiple links a multiplexing protocol is required for the communication between the devices, the BlueRS+ and the host. The BlueRS+ has to be adjusted to the routing scheme of the protocol to transmit the data in an appropriate way. This includes Bluetooth connection control (i.e. are the Bluetooth links permanently active or only on demand) and data distribution (i.e. are all data from the host to be forwarded to all devices or only depending on the address header; are data from the devices are transmitted to the host transparently or is an address header to be added). In case you have a multipoint application please contact Stollmann for specific support.

1.2.3 Terminal Server

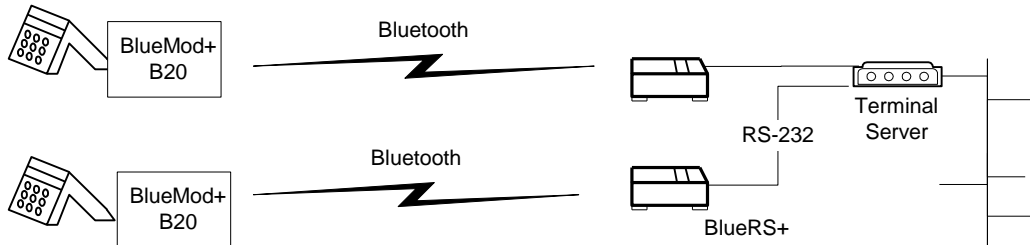

1.2.4 PC Client

The BlueMod+B20/AI, BlueMod+B20/AP/L or BlueMod+B20/AP can be used as a Bluetooth Client and as such can establish connections with other Bluetooth interfaces, e.g. in PCs.

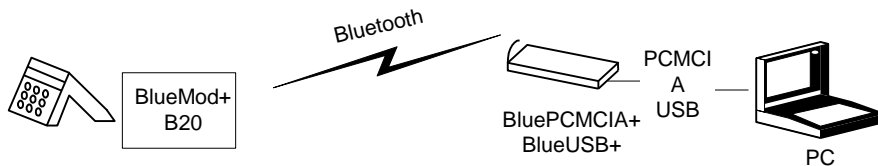

2 Block Diagram

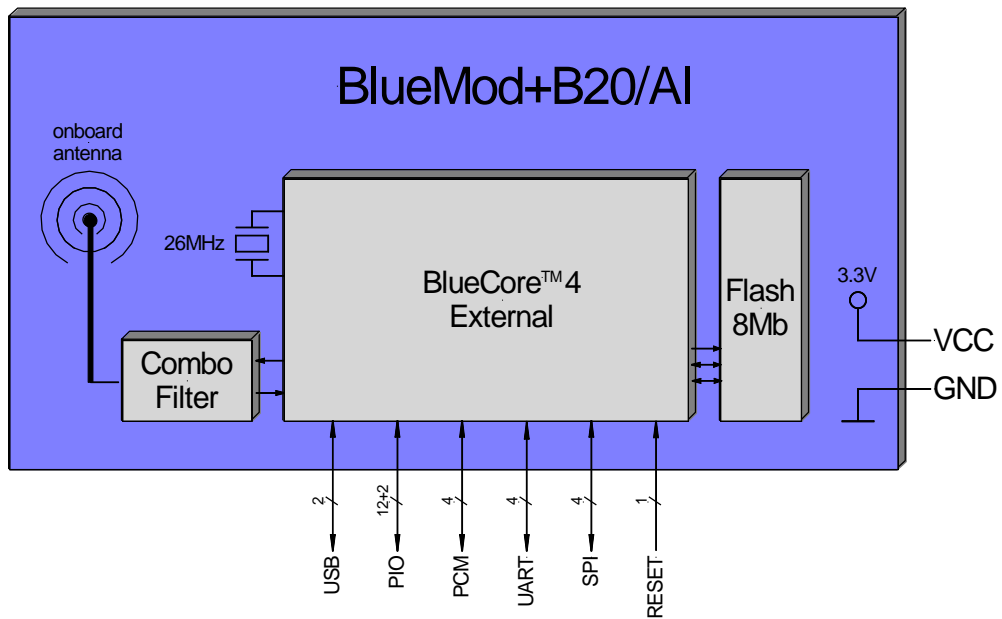

Figure: BlueMod+B20/AI block diagram

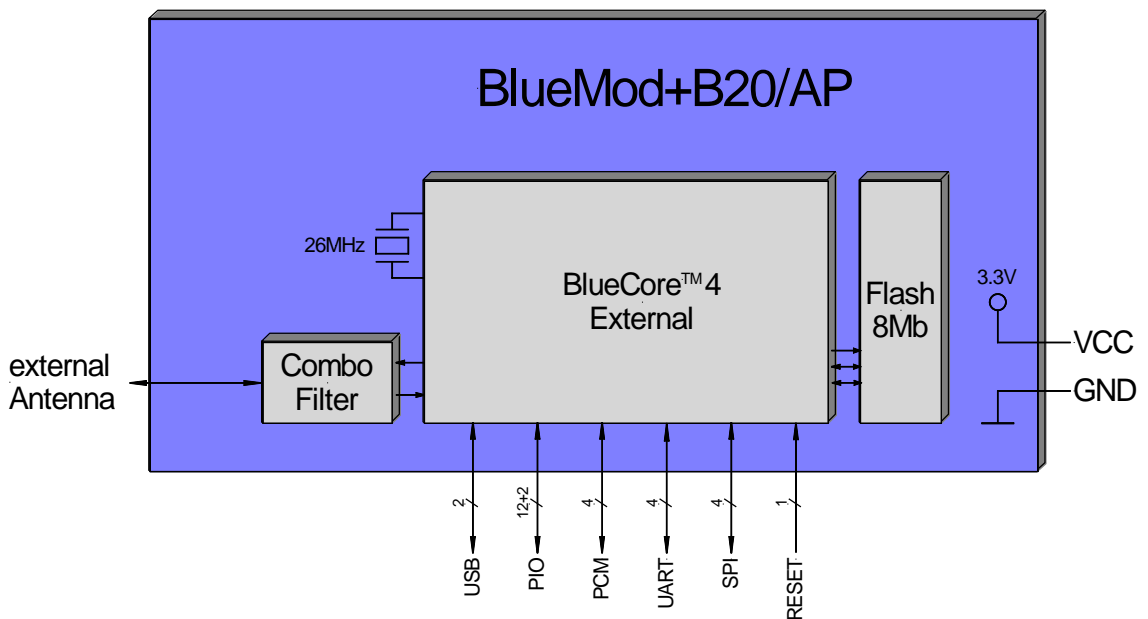

Figure: BlueMod+B20/AP, BlueMod+B20/AP/L block diagram

3 Application Interface

3.1 Power Supply

BlueMod+B20/AI, BlueMod+B20/AP/L and BlueMod+B20/AP require a power supply with the following characteristics:

Typical : 3.3VDC, min.: 2.8VDC – max.: 3.6VDC, low noise ($\leq 10\text{mV}$), $>80\text{mA}$ peak

Due to the technological requirements and the pulsed radio transmission the supply needs to be fed by an ultra fast (response time $\leq 20\mu\text{s}$) linear regulator placed as close as possible to the VSUP pin (22). Functionality has been verified with the following types: TOREX: XC6204x332xx or XC6401xx42xx

It is also recommended to place a low ESR capacitor with at least $10\mu\text{F}$ as close as possible to the VSUP pin (22).

NOTE: You must ensure that during operation the supply voltage never drops below 2.8 VDC. Otherwise the flash contents (firmware and/or configuration data) can get lost.

3.2 Reset

BlueMod+B20/AI, BlueMod+B20/AP/L and BlueMod+B20/AP are equipped with circuitry for generating Power ON Reset from the internal core voltage. A reset is generated when the core voltage falls below typically 1.5V and is released when it rises above typically 1.6V.

Via Pin 31 an external reset is generated by holding RESET# at $\leq 0.3V$ for $\geq 5ms$.

It is strongly recommended to use external Power ON Reset circuitry, which holds RESET# at $\leq 0.3V$ for $\geq 5ms$ after VSUP has stabilized in the recommended voltage range.

The following table shows the pin states of BlueMod+B20 on reset.

Pin Name	State: BlueMod+B20
PIO[11:0]	Input with weak pull down
PCM_OUT	Output tri-stated with weak pull down
PCM_IN	Input with weak pull down
PCM_SYNC	Input with weak pull down
PCM_CLK	Input with weak pull down
UART_TX	Output tri-stated with weak pull up
UART_RX	Input with weak pull down
UART_RTS#	Output tri-stated with weak pull up
UART_CTS#	Input with weak pull down
USB_DP	Input with weak pull down
USB_DN	Input with weak pull down
SPI_CS#	Input with weak pull up
SPI_CLK	Input with weak pull down
SPI_MOSI	Input with weak pull down
SPI_MISO	Output tri-stated with weak pull down
AIO[2:0]	Output, driving low
RESET#	Input with weak pull up

3.2.1 UART configuration in reset

The UART interface for BlueMod+B20 while the chip is being held in reset is tristate. This will allow the user to daisy chain devices onto the physical UART bus. The constraint on this method is that any devices connected to this bus must tristate when BlueMod+B20 reset is de-asserted and the firmware begins to run.

3.3 Serial Interface

The functionality of the interface corresponds to the V.24 / RS-232 standard on TTL-level.

- Transmission speeds are 1200 – 2764800 bps (asynchronous)
- Character representation: 8 Bit, even/odd/no parity, 1 or 2 stop bits
- Hardware flow-control with UART_RTS and UART_CTS (active low)

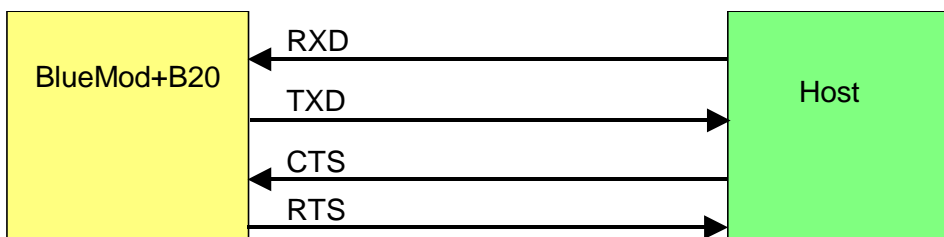

3.3.1 3-wire Serial Interface

When using only GND and UART_Rx, UART_Tx serial lines, leave UART_RTS# open and connect UART_CTS# to ground via 10k resistor.

Note: It is strongly recommended to use hardware flow control. Not using flow control can cause a buffer overflow in the Bluetooth module which blocks the module. Furthermore a loss of data is possible.

3.3.2 Baudrate tolerance

The following table shows the deviation in percent of the standard data rates.

Data Rate (bits/s)	Deviation (%)
1200	1.73
2400	1.73
4800	1.73
9600	-0.82
19200	0.45
38400	-0.18
57600	0.03
115200	0.03
230400	0.03
460800	-0.02
921600	0.00

Note: The total deviation of sender and receiver shall not exceed 2.5 % to prevent loss of data.

3.4 PIO Interface

It is possible to use the programmable digital I/Os PIO[0:11] and the programmable analog I/Os AIO[0:1] on the BlueMod+B20. Their behavior has to be defined project specific in the firmware.

3.5 I²C Interface

PIO[8:6] can be used to form a master I²C interface. The interface is formed using software to drive these lines. Therefore, it is suited only to relatively slow functions i.e. EEPROM.

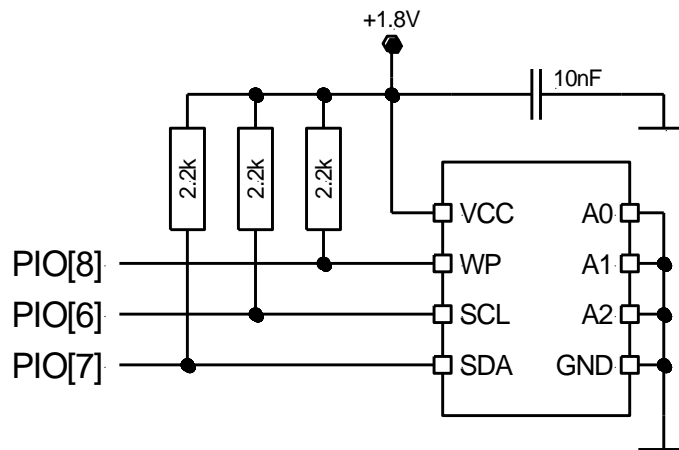

Example EEPROM connection

The BlueMod+B20/AI, BlueMod+B20/AP/L and BlueMod+B20/AP interface directly to EEPROM devices including the following:

- Atmel AT24Cxxx
- Catalyst CAT24WCxxx
- Fairchild FM24Cxxx
- Microchip 24AAxxx
- Philips PCF8582C-2, PCF8594C-2, PCF8598C-2
- Seiko 24Cxx, 24CSxx
- Rohm BR24Cxx
- ST M24C32, M24C64, M24128-B, M24256-B, M24512

3.6 Bluetooth radio Interface

- The BlueMod+B20/AI presents an integrated ceramic antenna.
- The BlueMod+B20/AP and BlueMod+B20/AP/L presents no integrated ceramic antenna whereas provides a 50Ω RF interface.

It is highly recommended that you follow the design rule given in the Stollmann Application Note on Antenna design [2].

3.7 PCM Interface

PCM or Pulse Code Modulation is a sampling technique for digitising analogue signals.

The PCM interface for voice applications is provided via the PCM_OUT, PCM_IN, PCM_CLK and PCM_SYNC pins.

The PCM interface can act as master or as slave device.

In master mode, clock frequencies of 128kHz, 256kHz or 512kHz can be generated, when using the internal 4MHz clock. In slave mode, clock frequencies up to 2048kHz are accepted.

The Frame Clock is 8kHz. Long and Short Frame Sync are supported.

Both BlueMod+B20/AI, BlueMod+B20/AP/L and BlueMod+B20/AP interface directly to PCM audio devices including the following:

- Qualcomm MSM3000 series and MSM5000 series CDMA base band devices
- OKI MSM7705 four channel A-law and μ -law codec
- Motorola MC145481 8-bit A-law and μ -law codec
- Motorola MC145483 13-bit linear codec
- STW 5093 5094 14-bit linear codec

3.8 USB Interface

3.8.1 D+, D-

Both BlueMod+B20/AI, BlueMod+B20/AP/L and BlueMod+B20/AP contain a full speed USB version 1.1 compliant interface capable of directly driving an USB cable. The BlueMod+B20 operates as a USB peripheral and responds to requests from a USB master host controller.

3.8.2 USB Self-Powered Mode

In USB self-powered mode, the BlueMod+B20 is powered from its own power supply and not from the USB Vbus line. In order to detect when the USB Vbus line is powered up, the USB Vbus line is monitored by PIO4 through a voltage divider.

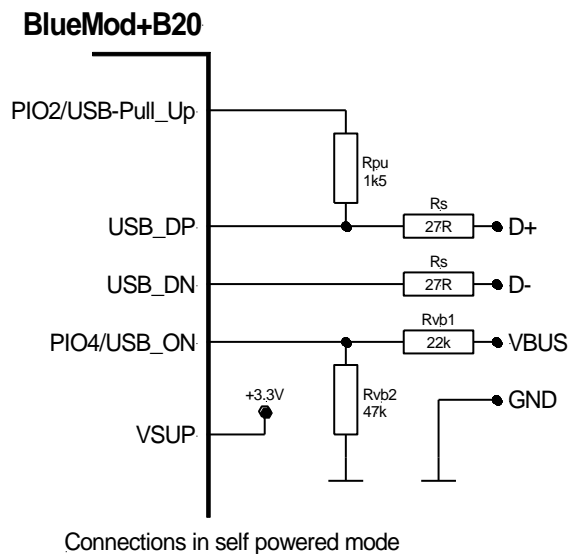

In self powered mode a 1.5K Ω pull up resistor needs to be connected between PIO2 and the USB D+ line. This pulls the USB D+ line high when the BlueMod+B20 is ready for enumeration, signaling to the host controller that the BlueMod+B20 is a full speed (12Mbps) USB device.

3.8.3 USB Bus-Powered Mode

In USB bus-powered mode, the BlueMod+B20 is powered from the USB Vbus line by means of a Low Drop Out (LDO) Voltage Regulator. When choosing the LDO Voltage Regulator for supplying the +3.3V power to the BlueMod+B20, some factors that need to be considered are:

- The voltage specification for the USB Vbus line is +4.75V to +5.25V.
- The total current required (average and peak) for the design.
- The voltage regulator's drop out voltage vs. output current.
- The voltage regulator's power dissipation over the operating temperature range.
- Filtering requirements on the USB Vbus line to attenuate noise above the voltage regulator's bandwidth.
- The suspend state current draw.

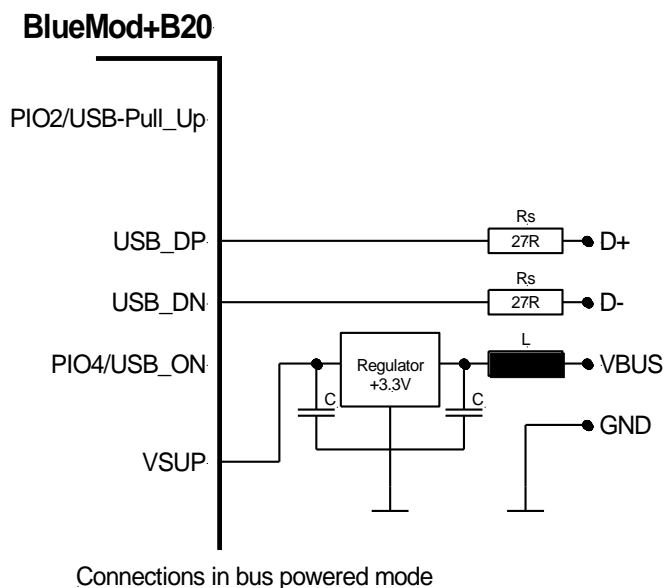

In bus powered mode an internal pull up resistor can be used. For details see related Software- or Interface- description.

3.9 Serial Peripheral Interface

BlueMod+B20 uses a 16-bit-data and 16-bit-address **S**erial **P**eripheral Interface (SPI). This interface is used for configuration, firmware flash and debug purposes only.

SPI Interface Cable

SPI Signal Name	B20 Pin	LPT Sub-D 25 Pin
MISO	30	10
MOSI	27	8
CLK	28	9
CS#	29	2
XAP_RESET	31	16
GND	2,21,34,35	18, 19

Note: It is highly recommended to make the SPI accessible in your design to ensure a future firmware upgrade for your module!

4 Pin Description

4.1 Pin Numbering

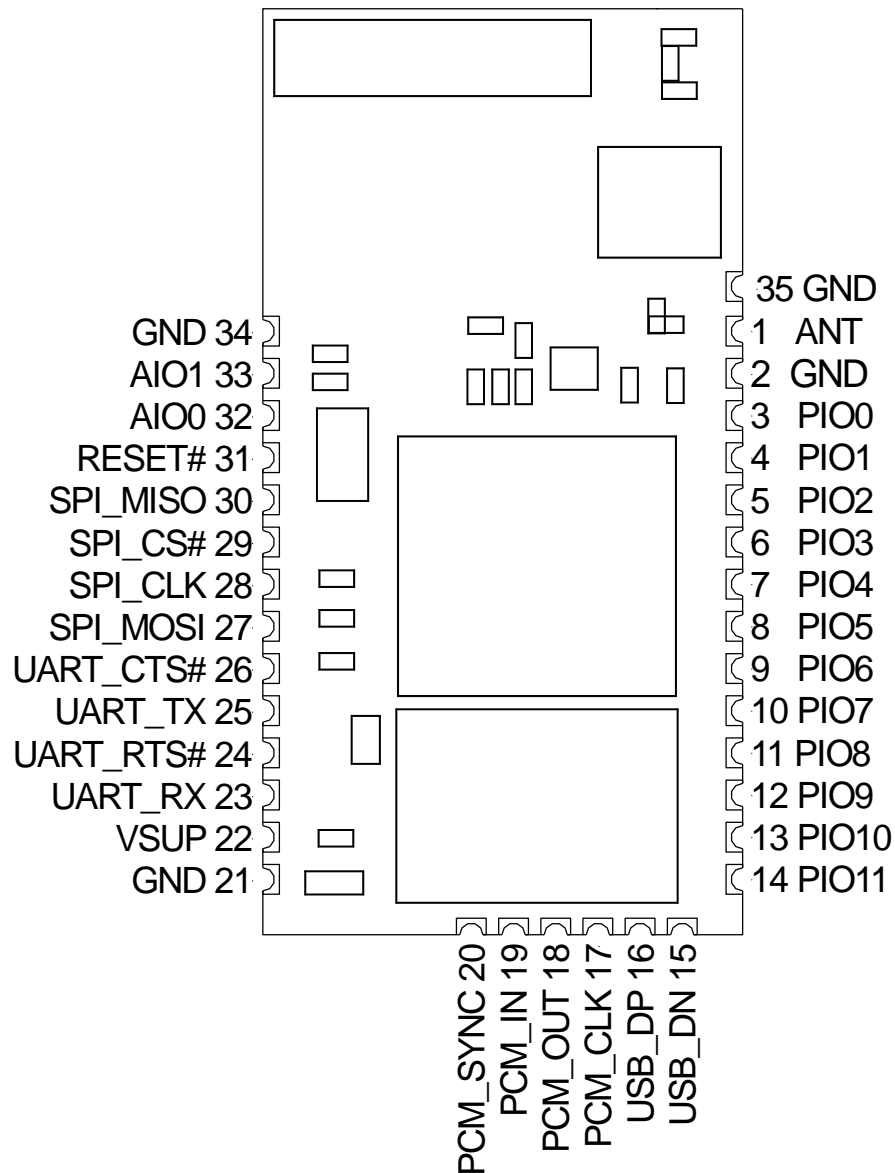

Figure 4.1 BlueMod+B20/AI, BlueMod+B20/AP/L Pin Numbering

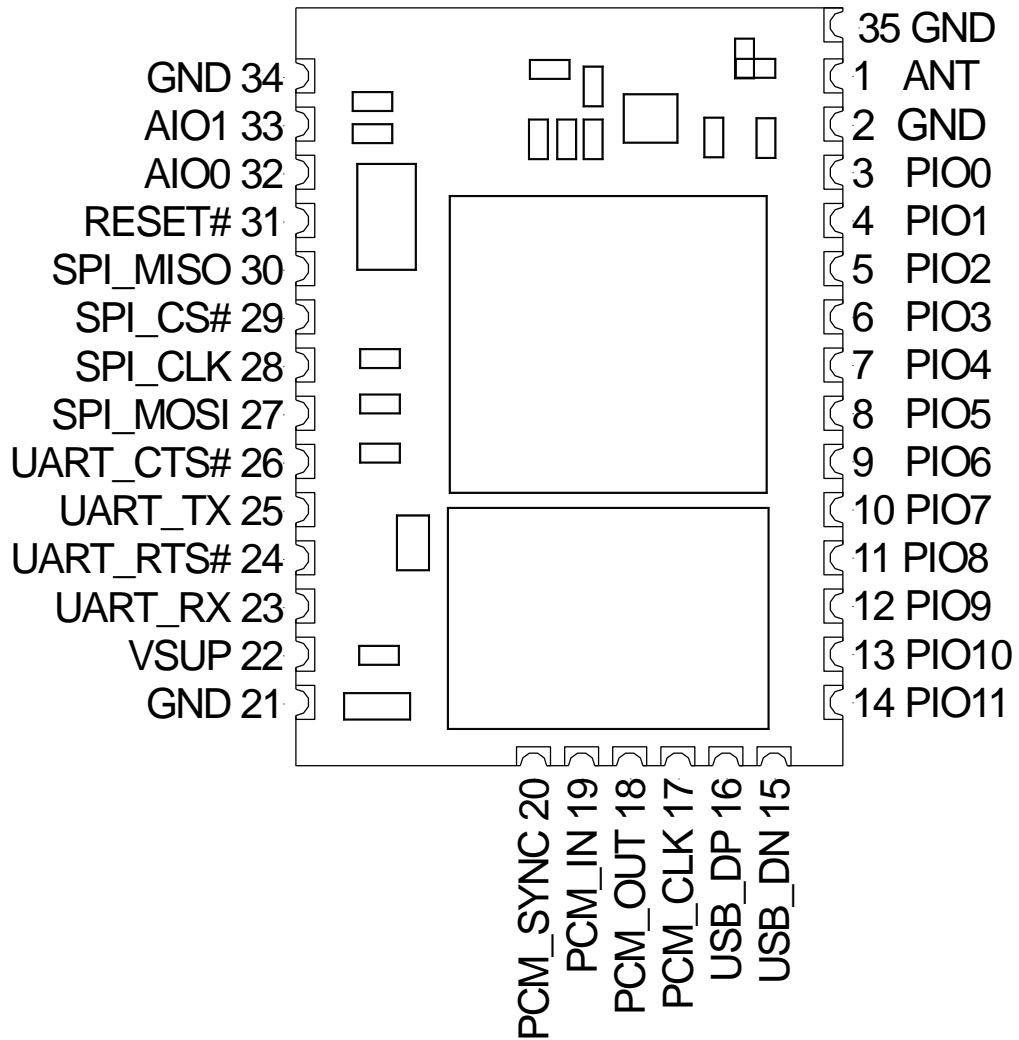

Figure 4.2 BlueMod+B20/AP Pin Numbering

4.2 Pin Description

4.2.1 General Pin Description

No	Pin Name	Type	Active	Description
1	NC			BlueMod+B20/AI Not Connected
1	ANT	I/O	-	BlueMod+B20/AP only, Antenna Pin 50Ω for external Antenna
2	GND	P	-	Ground
3	PIO0/RXEN	I/O	H	PIO/Control output for external LNA
4	PIO1/TXEN	I/O	H	PIO/Control output for ext. PA (class1)
5	PIO2/USB_Pull_Up	I/O	H	PIO/USB pull up in self powered mode
6	PIO3/USB_Wake_Up	I/O	H	PIO/USB output, to wake up PC when in USB mode
7	PIO4/USB_ON	I/O	H	PIO/USB input, VBUS detect in self powered mode
8	PIO5/USB_Detach	I/O	H	PIO/USB input, detaches from USB
9	PIO6/SCL	I/O	-	PIO/ I ² C Serial Clock
10	PIO7/SDA	I/O	-	PIO/ I ² C Serial data
11	PIO8/WP	I/O	-	PIO/ I ² C Write Protect
12	PIO9	I/O	-	PIO
13	PIO10	I/O	-	PIO
14	PIO11	I/O	-	PIO
15	USB_DN	I/O	-	USB Data-
16	USB_DP	I/O	-	USB Data+
17	PCM_CLK	I/O	-	PCM Bit clock
18	PCM_OUT	O	-	PCM Data Output
19	PCM_IN	I	-	PCM Data Input
20	PCM_SYNC	I/O	-	PCM Frame Sync
21	GND	P	-	Ground
22	VSUP	P	-	3.3V Supply Voltage
23	UART_RX	I	-	UART Asynchronous Receive Data
24	UART_RTS#	O	L	UART Request To Send
25	UART_TX	O	-	UART Asynchronous Transmit Data
26	UART_CTS#	I	L	UART Clear To Send
27	SPI_MOSI	I	-	Synchronous Peripheral Interface Data Master Out – Slave In
28	SPI_CLK	I	-	Synchronous Peripheral Interface Clock
29	SPI_CS#	I	L	Synchronous Peripheral Interface Chip Select
30	SPI_MISO	O	-	Synchronous Peripheral Interface Data Master In- Slave Out
31	RESET#	I	L	Module Reset
32	AIO0	I/O	-	Analogue Input/Output
33	AIO1	I/O	-	Analogue Input/Output
34	GND	P	-	Ground
35	GND	P	-	Ground

Type: PU - Pulled up; PD – pulled down; P – Power; I – Input; O – Output; I/O - bidirectional

4.2.2 Application Specific Pin Description

4.2.2.1 SPP Pin Configuration DCE Mode

No	Pin name	Pin function	Type	Active	Description
1	NC	NC			BlueMod+B20/AI Not Connected
1	ANT	ANT	I/O		BlueMod+B20/AP only, Antenna Pin 50Ω for external Antenna
2	GND	GND	P	-	Ground
3	PIO0	reserved	I-PU	-	Leave open
4	PIO1	reserved	I-PU	-	Leave open
5	PIO2	LED1#	O	L	Status LED 1 "Bluetooth connected" flashes when a Bluetooth link is established Use or leave open
6	PIO3	DCD#	O	L	Data Carrier Detect Output Use or leave open
7	PIO4	RTC-IN#	I-PD	L	DTR – Data Terminal Ready Use or leave open
8	PIO5	RTC-OUT#	O	L	DSR – Data Set Ready; Use or leave open
9	PIO6	RI# or SCL ¹	O	L	RING Output or I2C Serial Clock Use or leave open In case of I2C Serial Clock 2.2k Pull-up
10	PIO7	SDA ¹	I/O-PU	-	I2C Serial Data Use or leave open In case of I2C Serial Data 2.2k Pull-up
11	PIO8	WP ¹	O	-	I2C Write Protect Use or leave open In case of I2C Write Protect 2.2k Pull-up
12	PIO9	reserved	O		Leave open
13	PIO10	reserved	O		Leave open
14	PIO11	reserved	I-PU		Leave open
15	USB_DN	reserved	I-PD	-	Leave open
16	USB_DP	reserved	I-PD	-	Leave open
17	PCM_CLK	reserved	I-PD	-	Leave open
18	PCM_OUT	reserved	O	-	Leave open
19	PCM_IN	reserved	I-PD	-	Leave open
20	PCM_SYNC	reserved	I-PD	-	Leave open
21	GND	GND	P	-	Ground
22	VSUP	VSUP	P	-	3.3V Supply Voltage
23	UART_RX	UART_RX	I-PD	-	UART Asynchronous Receive Data
24	UART_RTS#	UART_RTS#	O	L	UART Request To Send Use for flow control
25	UART_TX	UART_TX	O	-	UART Asynchronous Transmit Data
26	UART_CTS#	UART_CTS#	I-PD	L	UART Clear To Send Use for flow control
27	SPI_MOSI	SPI_MOSI	I-PD	-	SPI Data Input Connector, Test-Point for FW-FLASH

¹ subject to firmware support, contact Stollmann for current status.

Hardware Reference

28	SPI_CLK	SPI_CLK	I-PD	-	SPI Clock Connector, Test-Point for FW-FLASH
29	SPI_CS#	SPI_CS#	I-PU	L	SPI Chip Select Input Connector, Test-Point for FW-FLASH
30	SPI_MISO	SPI_MISO	O		SPI Data Output Connector, Test-Point for FW-FLASH
31	RESET#	RESET#	I-PU	L	Module Reset Connect to RESET Controller
34	GND	GND	P	-	Ground
35	GND	GND	P	-	Ground

4.2.2.2 SPP Pin Configuration DTE Mode

No	Pin Name	Pin Function	Type	Active	Description
1	NC	NC			BlueMod+B20/AI Not Connected
1	ANT	ANT	I/O		BlueMod+B20/AP only, Antenna Pin 50Ω for external Antenna
2	GND	GND	P	-	Ground
3	PIO0	reserved	I-PU	-	Leave open
4	PIO1	reserved	I-PU	-	Leave open
5	PIO2	LED1#	O	L	Status LED 1 "Bluetooth connected" flashes when a Bluetooth link is established Use or leave open
6	PIO3	DCD#	I-PD	L	Data Carrier Detect Input Use or leave open
7	PIO4	RTC-IN#	I-PD	L	DSR – Data Set Ready Use or leave open
8	PIO5	RTC-OUT#	O	L	DTR – Data Terminal Ready Use or leave open
9	PIO6	RI# or SCL ²	I-PU	L	RING Input in DTE mode or I2C Serial Clock In case of I2C Serial Clock 2.2k Pull-up
10	PIO7	SDA ²	I/O-PU	-	I2C Serial Data Use or leave open In case of I2C Serial Data 2.2k Pull-up
11	PIO8	WP ²	O	-	I2C Write Protect Use or leave open In case of I2C Write Protect 2.2k Pull-up
12	PIO9	reserved	O		Leave open
13	PIO10	reserved	O		Leave open
14	PIO11	reserved	I-PU		Leave open
15	USB_DN	reserved	I-PD	-	Leave open
16	USB_DP	reserved	I-PD	-	Leave open
17	PCM_CLK	reserved	IPD	-	Leave open
18	PCM_OUT	reserved	O	-	Leave open
19	PCM_IN	reserved	I-PD	-	Leave open
20	PCM_SYNC	reserved	I-PD	-	Leave open
21	GND	GND	P	-	Ground
22	VSUP	VSUP	P	-	3.3V Supply Voltage
23	UART_RX	UART_RX	I-PD	-	UART Asynchronous Receive Data
24	UART_RTS#	UART_RTS#	O	L	UART Request To Send Use for flow control
25	UART_TX	UART_TX	O	-	UART Asynchronous Transmit Data
26	UART_CTS#	UART_CTS#	I-PD	L	UART Clear To Send Use for flow control
27	SPI_MOSI	SPI_MOSI	I-PD	-	SPI Data Input Connector, Test-Point for FW-FLASH, PSTOOLS
28	SPI_CLK	SPI_CLK	I-PD	-	SPI Clock Connector, Test-Point for FW-FLASH, PSTOOLS

² subject to firmware support, contact Stollmann for current status.

Hardware Reference

29	SPI_CS#	SPI_CS#	I-PU	L	SPI Chip Select Input Connector, Test-Point for FW-FLASH, PSTOOLS
30	SPI_MISO	SPI_MISO	O		SPI Data Output Connector, Test-Point for FW-FLASH, PSTOOLS
31	RESET#	RESET#	I-PU	L	Module Reset Connect to RESET Controller
34	GND	GND	P	-	Ground
35	GND	GND	P	-	Ground

5 Electrical Characteristics

5.1 Absolute Maximum Ratings

Stresses beyond those listed under “Absolute Maximum Ratings” may cause permanent damage to the device. These are stress ratings only, and functional operation of the device at these or any other conditions beyond those indicated under “Electrical Requirements” is not implied. Exposure to absolute-maximum-rated conditions for extended periods may affect device reliability.

Item	Symbol	Absolute Maximum Ratings	Unit
Supply voltage	V _{SUP}	-0.4 to +3.7	V
Voltage on any pin	V _{Pin}	GND -0.3 to VSUP +0.4	V

5.2 Electrical Requirements

VSUP = 3.3V, T_{amb} = 25°C if nothing else stated

Item	Condition	Limit			Unit
		Min	Typ	Max	
Frequency Range		2400		2483.5	MHz
Load impedance	Measured with network analyzer in the frequency range at antenna pin		50		Ohm
Output return loss	Receive Mode to 50Ω load	-10			dBm
	Transmit Mode to 50Ω load	-10			
Supply voltage VSUP	The typical voltage is recommended VSUP at voltage pin	2.8	3.3	3.6	Vdc
Ripple on Vcc	Ripple frequency ≤10MHz			10	mVrms

5.3 Environmental Requirements

Item	Symbol	Absolute Maximum Ratings	Unit
Storage temperature range	T _{stg}	-40 to +105	°C
Operating temperature range commercial variant /C	T _{op}	-0 to +70	°C
Operating temperature range industrial variant /I	T _{op}	-40 to +85	°C

5.4 Digital I/O including RESET#

$V_{SUP} = 3.3V$, $T_{amb} = 25^{\circ}C$

Symbol	Item	Condition	Limit			Unit
			Min	Typ	Max	
V_{IL}	Low-Level Input Voltage	$V_{SUP} = 3.3V$	- 0.4	-	0.8	V
V_{IH}	High-Level Input Voltage		$0.7 \times V_{SUP}$	-	-	V
V_{OL}	Low-Level Output Voltage	$I_{OL} = 4mA$	-	-	0.2	V
V_{OH}	High-Level Output Voltage	$I_{OH} = -4mA$	$V_{SUP} - 0.2$	-	-	V
I_{OL}	Low -Level Output Current	$V_{OL} = 0.55V$	-	-	4	mA
I_{OH}	High-Level Output Current	$V_{OH} = 2.3V / 100k$ PU $V_{OH} = 2.3V / 10k$ PU	-	-	-4	mA
I_{sp-u}	Input-current	Strong pull-up	-100	-40	-10	μA
I_{sp-d}	Input-current	Strong pull-down	+10	+40	++100	μA
I_{wp-u}	Input-current	Weak pull-up	-5.0	-1.0	-0.2	μA
I_{wp-d}	Input-current	Weak pull-down	+0.2	-1.0	+5.0	μA
I_{lc}	I/O pad leakage current		-1	0	+1	μA
C_I	Input Capacitance		1.0	-	5.0	pF

5.5 AIO-Interface

$V_{SUP} = 3.3V$, $T_{amb} = 25^{\circ}C$

Item	Limit			Unit
	Min	Typ	Max	
Resolution	-	-	8	Bits
Input voltage range	0		1.7	V
Accuracy	-1		1	LSB
Offset	-1		1	LSB
Gain error	-0.8		0.8	%
Input bandwidth		100		kHz
Conversion time	-	2.5	-	μs
Sample rate			700	Samples/s

5.6 USB-Interface

$V_{SUP} = 3.3V$, $T_{amb} = 25^{\circ}C$

Item			Unit
	Min	Max	
Input logic level low	-	$0.3 \times V_{SUP}$	V
Input logic level high	$0.7 \times V_{SUP}$	-	V
Output logic level low)*	0	0.2	V
Output logic level high)*	2.8	V_{SUP}	V

)* connected to correctly terminated USB cable

5.7 Power consumption and power down modes

5.7.1 HCI Configuration

tbd

5.7.2 SPP Configuration

The following values are approximate power consumption values in the different states:

$V_{SUP} = 3.3V$, $T_{amb} = 25^{\circ}C$

Condition	Device Role		Unit
	Master	Slave	
Idle, no page scan, no inquiry scan, Uart baud rate: 1200 baud	1,4	--	mA
Idle, all functions available, no Bluetooth link, page scan & inquiry scan interval 1,28s	2,5	--	mA
Idle, all functions available, no Bluetooth link, page scan & inquiry scan interval 11,25ms	41	--	mA
Bluetooth connected, no data traffic – close range	6	21	mA
Bluetooth connected, data traffic 115,2 kbit/s – close range	30	32,5	mA
Bluetooth connected, data traffic 230,4 kbit/s – close range	35	--	mA
Sniff Mode (250ms) Bluetooth connected, no data traffic – close range	4,4	4,1	mA
Sniff Mode (500ms) Bluetooth connected, no data traffic – close range	3,7	3,3	mA
Sniff Mode (1000ms) Bluetooth connected, no data traffic – close range	3	2,7	mA
Device in reset	0,06	--	mA

5.8 RF performance

$V_{CC} = 3.3V$, $T_{amb} = +20^{\circ}C$, 50 Ω antenna

Receiver	Frequency [GHz]	Limit			BT Spec	Unit
		Min	Typ	Max		
Sensitivity at 0.1% BER	2.402	-83	-81	-78	≤ -70	dBm
	2.441	-83	-81	-78		
	2.480	-83	-81	-78		
Maximum received signal at 0.1% BER		-20	-	-	≥ -20	dBm
C/I co-channel BER (Wanted Signal -60dBm / Interferer -71dBm)		0.0	0.0002	-	≤ 0.1	%
Adjacent channel selectivity C/I $f = f_0 \pm 1MHz$ BER (Wanted Signal -60dBm / Interferer -60dBm)		0.0	0.0	0.04	≤ 0.1	%
Adjacent channel selectivity C/I $f = f_0 \pm 2MHz$ BER (Wanted Signal -60dBm / Interferer -30dBm)		0.0	0.0	0.04	≤ 0.1	%
Adjacent channel selectivity C/I $f \geq f_0 \pm 3MHz$ BER (Wanted Signal -67dBm / Interferer -27dBm)		0.0	0.03	0.04	≤ 0.1	%
Adjacent channel selectivity C/I $f = f_{image}$ BER (Wanted Signal -67dBm / Interferer -58dBm)		0.0	0.0	0.04	≤ 0.1	%

Transmitter	Limit			BT Spec	Unit
	Min	Typ	Max		
RF transmit power 50 Ω load, at antenna	0.6	1.7	2.8	-6 to +4	dBm
RF transmit power radiated	1.5	2.6	3.7	-6 to +4	dbm (EIRP)
RF power control range	25	35	-	≥ 16	dB
RF power range control resolution	2	4	6	2 to 8	dB
20 dB bandwidth for modulated carrier	-	.79	1.0	≤ 1.0	MHz
Initial carrier frequency tolerance	-75	0	+75	$\leq \pm 75$	kHz
Carrier frequency drift (packet DH1)	-	8	25	$\leq \pm 25$	kHz
Drift Rate	-	7	20	≤ 20	kHz/50 μ s
$\Delta f_{1_{avg}}$ "Maximum Modulation"	140	163	175	≥ 140 to ≤ 175	kHz
$\Delta f_{2_{avg}}$ "Minimum Modulation"	115	154	-	≥ 115	kHz
Adjacent channel Transmit power $f = f_0 \pm 2MHz$	-	-35	-20	≤ -20	dBc
Adjacent channel Transmit power $f = f_0 \pm 3MHz$	-	-45	-40	≤ -40	dBc

5.9 Power-up time

The time until the BlueMod+B20 is able to accept link requests or serial data is about 1.14 seconds after power-up.

6 Mechanical Characteristics

6.1 Dimensions

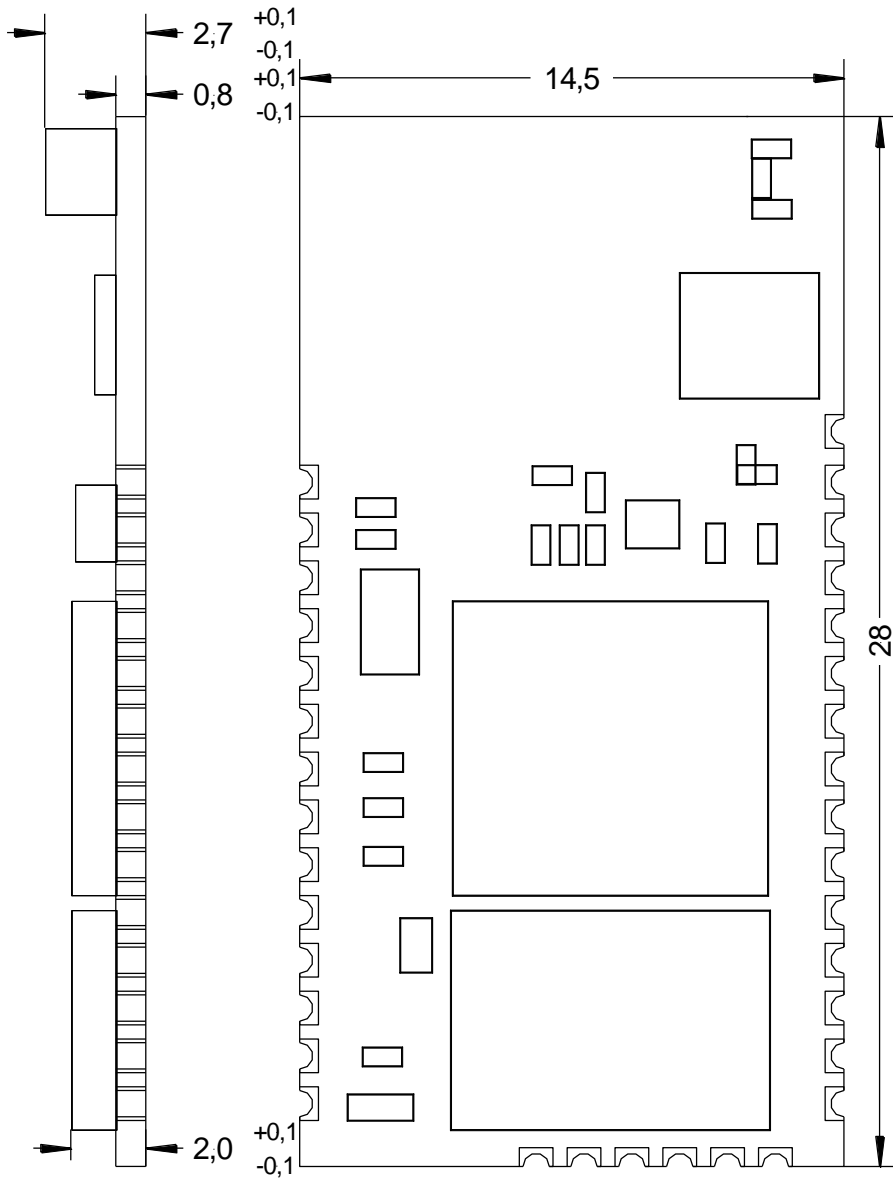

Figure 6.1 BlueMod+B20/Al and BlueMod+B20/AP/L dimensions

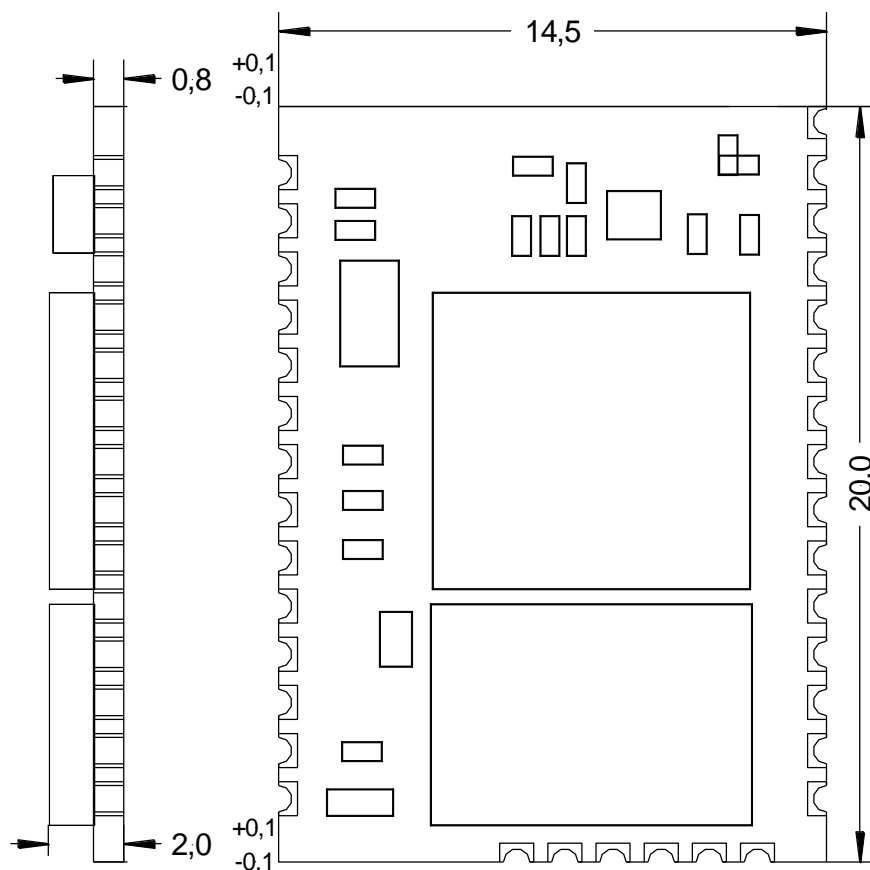

Figure 6.2 BlueMod+B20/AP dimensions

6.2 Recommended Land Pattern

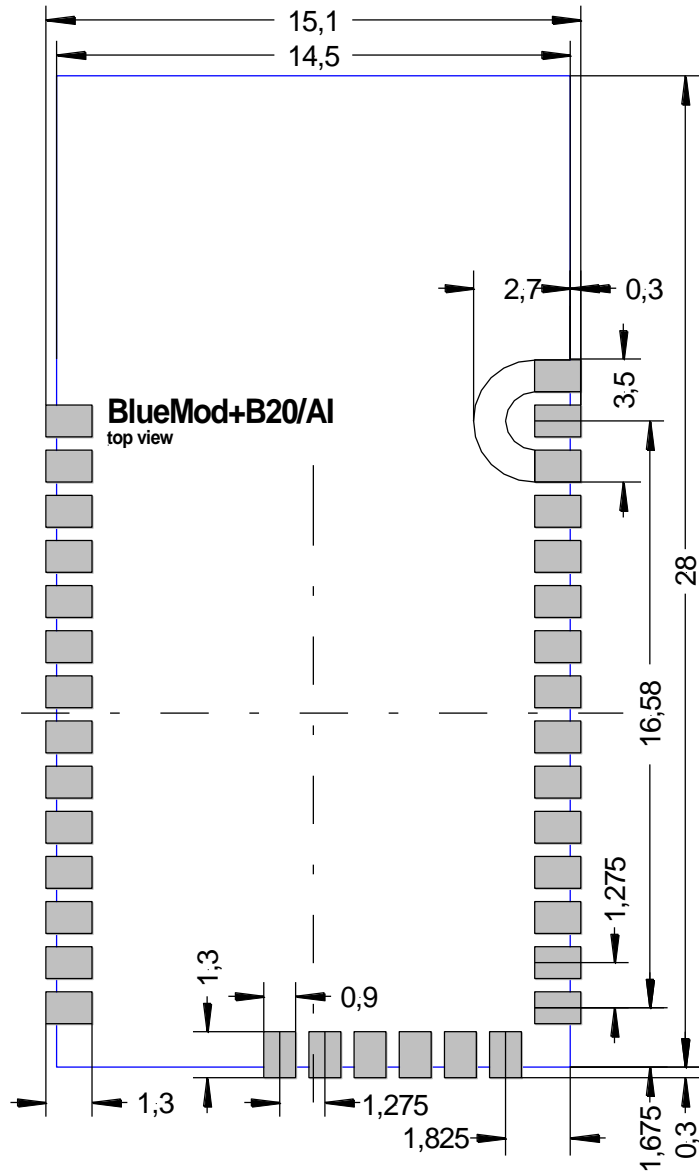

Figure 6.3 BlueMod+B20/AI and BlueMod+B20/AP/L land pattern

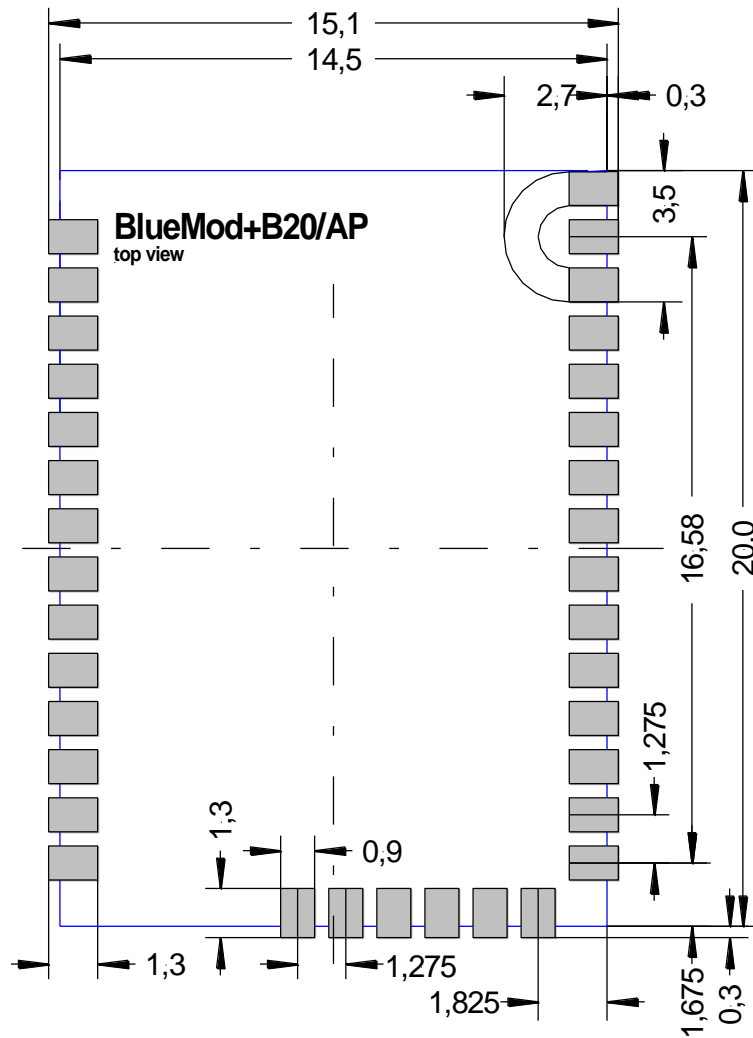
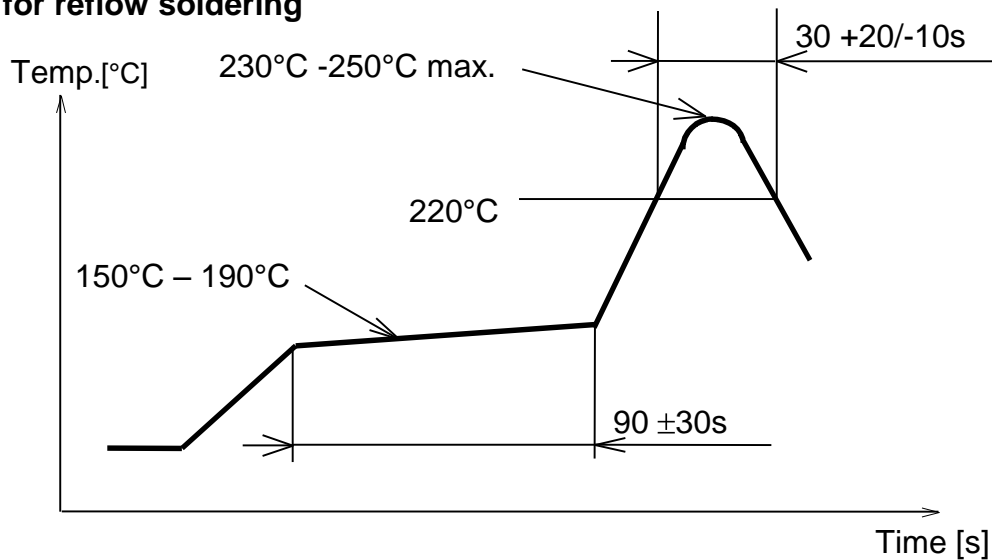

Figure 6.4 BlueMod+B20/AP land pattern

6.3 Re-flow Temperature-Time Profile

The data here is given only for guidance on solder and has to be adopted to your process and other re-flow parameters for example the used solder paste. The paste manufacturer provides a re-flow profile recommendation for his product.

Our used temp. profile for reflow soldering



Opposite side re-flow is prohibited due to module weight.

Devices will withstand the specified profile and will withstand up to 2 re-flows to a maximum temperature of 260°C.

6.4 Restricted Area

The mother board should have no bare conductors or vias in this restricted area, because it is not covered by stop mask print. Also no copper (planes, traces or vias) are allowed in this area, because of mismatching the on-board antenna.

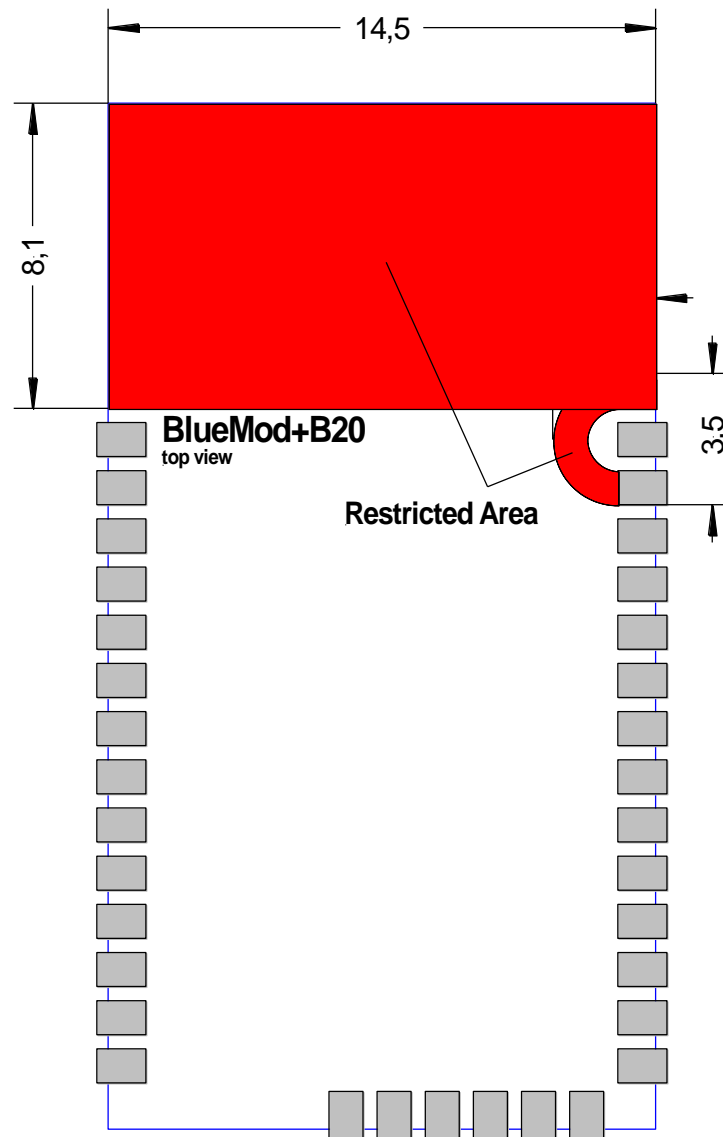

Figure 6.5 BlueMod+B20/AI and BlueMod+B20/AP/L Restricted Area

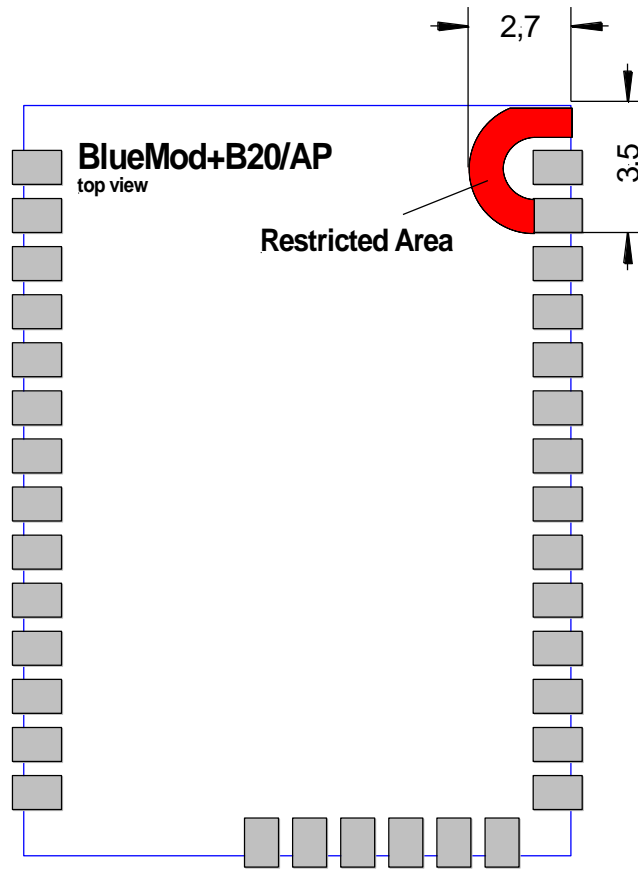

Figure 6.6 BlueMod+B20/AP Restricted Area

6.5 Housing Guidelines

The individual case must be checked to decide whether a specific housing is suitable for the use of the internal antenna. A plastic housing must at least fulfill the following requirements:

- Non-conductive material, non-RF-blocking plastics
- No metallic coating
- ABS is suggested

6.6 Antenna Issues

BlueMod+B20 is shipped with 2 different antenna designs:

- BlueMod+B20/AI comprises a ceramic antenna which as a component is soldered to the circuit board. This is functional for a BlueMod+B20/AI integrated into a plastic housing. No additional antenna is required.

For an external antenna to be set in, e.g. because the BlueMod+B20 is integrated into a metal housing, the ceramic antenna is replaced.

- BlueMod+B20/AP routes the antenna signal to pin 1.

The gain of the external antenna shall not exceed +2dBi.

When using an external Antenna the antenna is fixed and cannot be removed or replaced by the end user. The performance of the internal antenna respectively the external antenna has in any case to be checked within the final integration environment. Adjacent PCBs, components, cables, housings etc. could otherwise influence the radiation pattern or be influenced by the radio wave energy.

It must be ensured that the antenna is not co-located or operating in conjunction with any other antennas, transmitters, cables or connectors. When the internal ceramic antenna is used, certain restrictions are to be considered.

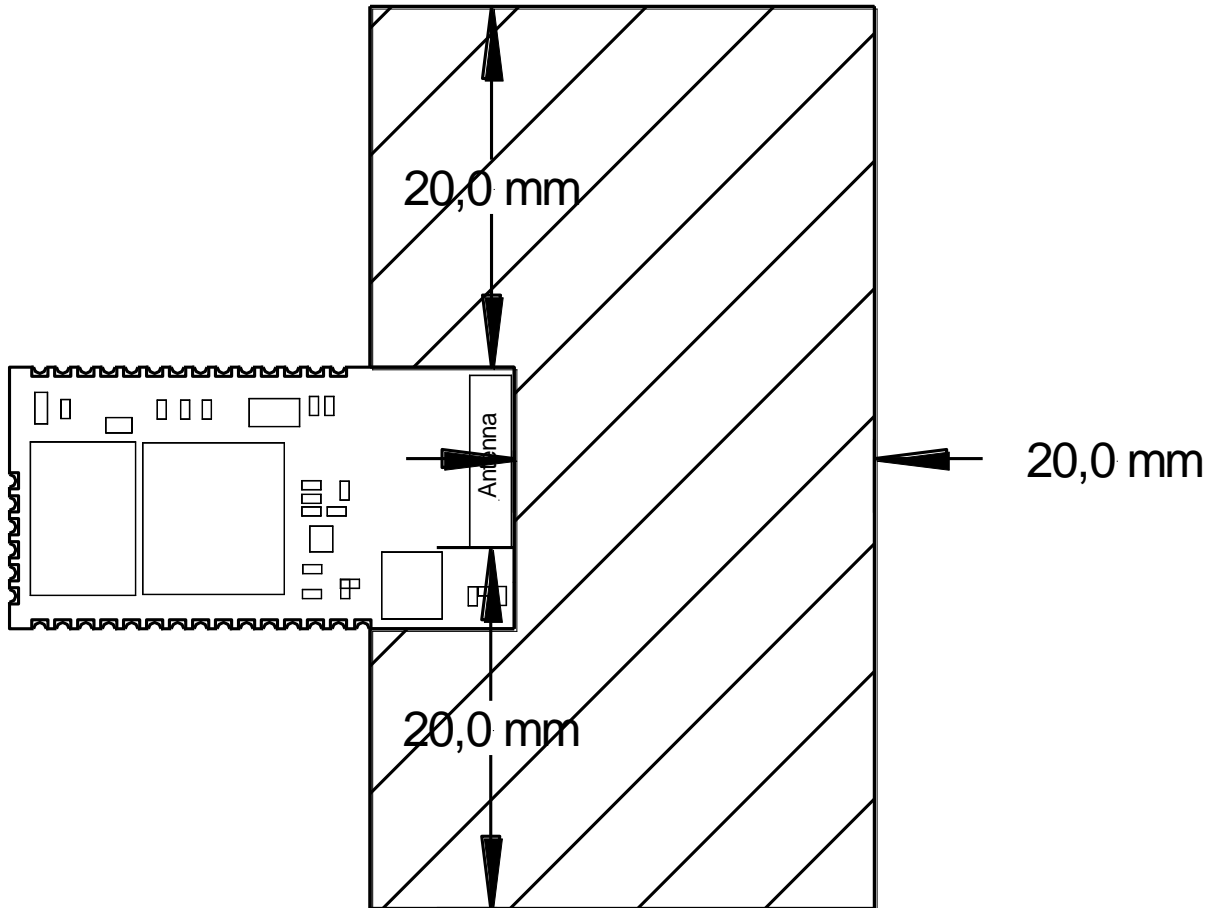

Figure 6.7 Antenna – recommended restricted area

To give an optimized antenna performance the restricted area having no ground or power planes, traces or parts should be widened. The following dimensions should be implemented, depending on your possible space.

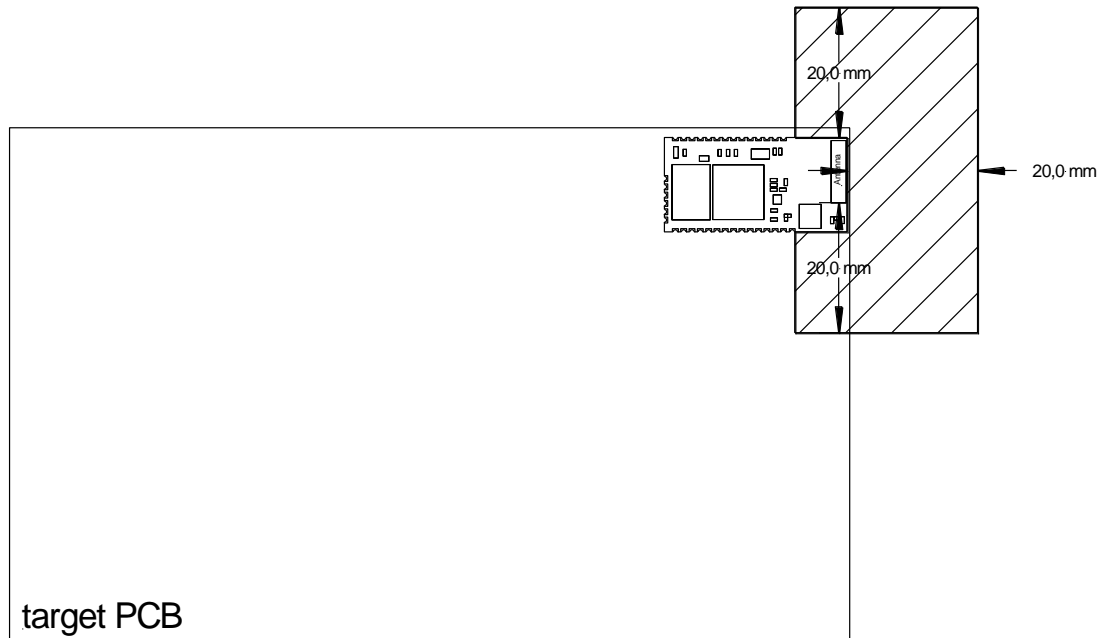

Figure 6.8 Optimal placement

The best position to place the BlueMod+B20/AI on the target PCB is in the upper right corner. This position is optimal concerning antenna interference; radiation pattern and PCB space that has to be kept free for the restricted area.

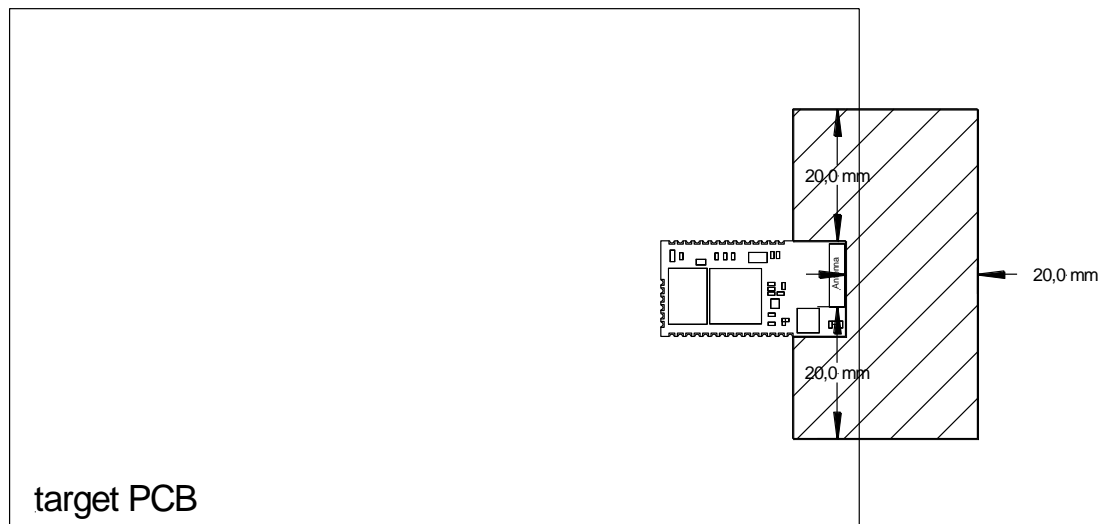

Figure 6.9 Recommendable placement

When placing the BlueMod+B20/AI at the right edge of the PCB ensure that the restricted area on the target PCB is free of planes, traces and parts.

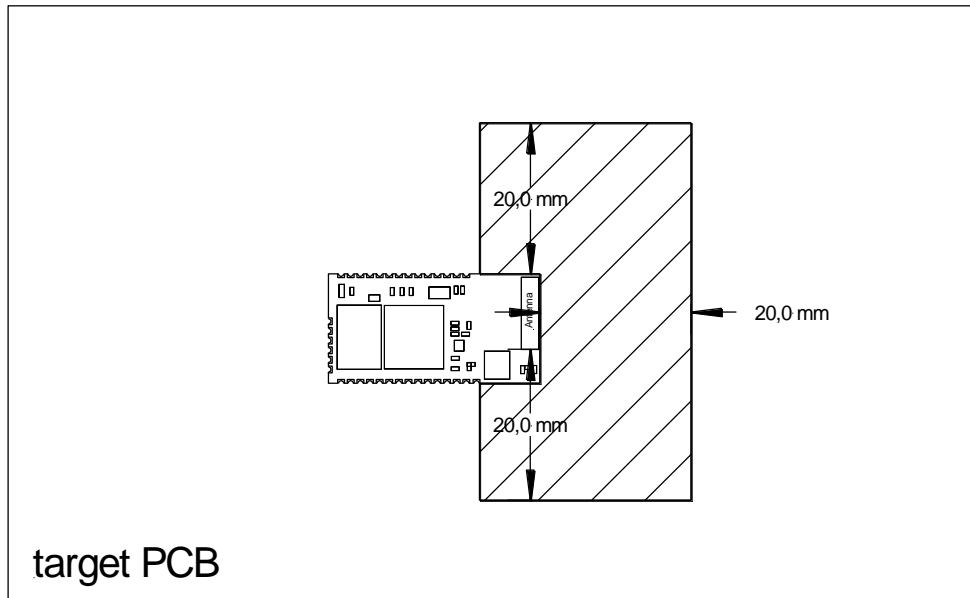

Figure 6.10 Acceptable, but not optimal placement

When placing the BlueMod+B20/AI on other positions than the right side the complete restricted area should be kept free of planes, traces and parts.

6.7 Safety Guidelines

According to SAR regulation EN 50371-2002 the BlueMod+B20/AI, BlueMod+B20/AP/L and BlueMod+B20/AP are not intended to be used in close proximity to the human body. Please refer to above-mentioned regulation for more specific information.

In respect to the safety regulation EN 60950-1: 2001 all conductive parts of the BlueMod+B20/AI, BlueMod+B20/AP/L and BlueMod+B20/AP are to be classified as SELV circuitry. OEM's implementing the BlueMod+B20 in their products should follow the isolation rules given in regulation EN 60950-1: 2001.

The PCB material of the BlueMod+B20/AI, BlueMod+B20/AP/L and BlueMod+B20/AP are classified UL-94V0.

7 Approvals/Certifications

7.1 Declaration of conformity

Konformitätserklärung gemäß dem Gesetz über Funkanlagen und Telekommunikationsendeinrichtungen (FTEG) und der Richtlinie 1999/5/EG (R&TTE)

Declaration of Conformity in accordance with Radio and Telecommunications Terminal Equipment Act (FTEG) and Directive 1999/5/EC (R&TTE Directive)

Stollmann Entwicklungs- und Vertriebs-GmbH, Mendelssohnstr. 15d, D-22761 Hamburg,
Jens Jensen

Hersteller/Verantwortliche Person // The manufacturer / responsible person

erklärt, daß die Produktfamilie

declares that the product family

BlueMod+B20 (with external antenna)
BlueMod+B29 (with internal Chip antenna)

Telekommunikationseinrichtung mit Verwendungszweck: Serielles Bluetooth Modul
Telecommunications terminal equipment with intended purpose: Serial Bluetooth Module

bei bestimmungsgemäßer Verwendung den grundlegenden Anforderungen des §3 und den übrigen einschlägigen Bestimmungen des FTEG (Artikel 3 der R&TTE) entspricht.

complies with the essential requirements of §3 and the other relevant provisions of the FTEG (Article 3 of the R&TTE Directive), when used for its intended purpose

Gesundheit und Sicherheit gemäß §3(1)1.(Artikel 3 (1) a))

Health and safety requirements pursuant to §3(1)1.(Article 3(1)a))

Ausgangsleistung ist kleiner 20mW

Output Power is lower than 20mW

angewendete harmonisierte Normen

harmonised standards applied

EN 60 950-1: 2006 (tested mounted on OK2061 built in plastic housing)

EN 50 371: 2002

Wenn der bestimmungsgemäße Betrieb des Endgerätes in das dieses Bluetooth Modul eingebaut wird vorsieht, dass dieses Endgerät am menschlichen Körper getragen wird, ist eine SAR Betrachtung dieses Endgerätes durchzuführen.

If the intended use of the OEM product integrating this Bluetooth Module allows to wear the OEM product on the human body, a SAR evaluation of the OEM product has to be conducted.

Schutzanforderungen in Bezug auf die elektromagnetische Verträglichkeit §3(1)2, Artikel 3(1)b))

Protection requirements concerning electromagnetic compatibility §3(1)2, (Article 3(1)b))

angewendete harmonisierte Normen

harmonised standards applied

EN 301 489-1 V1.8.1 (tested mounted on OK2061 built in plastic housing)

EN 301 489-17 V1.3.2 (tested mounted on OK2061 built in plastic housing)

EN 300 328-2 V1.7.1 (tested mounted on OK2061 built in plastic housing)

Elektromagnetische Verträglichkeit in Bezug auf das Radio Frequenz Spektrum

Electromagnetic compatibility and Radio Spectrum Matters (ERM)

Ort, Datum

Place & date of issue

Hamburg, den 04.05.2009
i.A.

Firmenstempel

Firm stamp

Stollmann Entwicklungs- und Vertriebs-GmbH
Mendelssohnstr. 15d
22761 Hamburg

Name, Unterschrift

Name and signature

7.2 FCC Compliance

The BlueMod+B20 has been tested to fulfill the FCC and IC requirements. Test reports are available on request. **The labeling requirements of the FCC and IC are fulfilled by the /FCC product variants only.** Please note that you must order these variants if you plan to deliver the module to the USA or Canada.

7.2.1 FCC Grant

TCB

GRANT OF EQUIPMENT
AUTHORIZATION
Certification
Issued Under the Authority of the
Federal Communications Commission
By:

TCB

CETECOM ICT Services GmbH
Untertuerheimer Strasse 6-10
D-66117 Saarbruecken,
Germany

Date of Grant: 03/28/2007
Application Dated: 03/28/2007

Stollmann E+V GmbH
Mendelssohnstrasse 15
Hamburg, 22761
Germany

Attention: Jens Jensen

NOT TRANSFERABLE

EQUIPMENT AUTHORIZATION is hereby issued to the named GRANTEE, and is VALID ONLY for the equipment identified hereon for use under the Commission's Rules and Regulations listed below.

FCC IDENTIFIER: RFR-B2029

Name of Grantee: Stollmann E+V GmbH

Equipment Class: Part 15 Spread Spectrum Transmitter

Notes: BT Module

Grant Notes	FCC Rule Parts	Frequency	Output	Frequency Tolerance	Emission Designator
		Range (MHZ)	Watts		
	15C	2402.0 - 2480.0	0.001		

Limited Modular Approval. Power Output listed is conducted. Approval is limited to OEM installation only. The antenna(s) used for this transmitter must not be co-located or operating in conjunction with any other antenna or transmitter. OEM integrators must be provided with antenna installation instructions. This OEM module is approved for use in products operating as mobile and portable transmitting device with respect to 2.1091 and 2.1093. OEM integrators and End-Users must be provided with transmitter operation conditions for satisfying RF exposure compliance. This grant is valid only when the device is sold to OEM integrators and the OEM integrators are instructed to ensure that the end user has no manual instructions to remove or install the device.

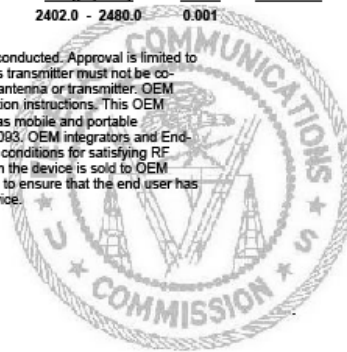

7.2.2 FCC/IC Statement

This device complies with Part 15 of the FCC Rules and with RSS-210 of Industry Canada.

Operation is subject to the following two conditions:

- (1) this device may not cause harmful interference, and
- (2) this device must accept any interference received, including interference that may cause undesired operation.

7.2.3 Caution

Warning: Changes or modifications made to this equipment not expressly approved by Stollmann Entwicklungs und Vertriebs GmbH may void the FCC authorization to operate this equipment.

7.2.4 FCC Warning

This equipment has been tested and found to comply with the limits for a Class B digital device, pursuant to Part 15 of the FCC Rules. These limits are designed to provide reasonable protection against harmful interference in a residential installation. This equipment generates, uses and can radiate radio frequency energy and, if not installed and used in accordance with the instructions, may cause harmful interference to radio communications. However, there is no guarantee that interference will not occur in a particular installation. If this equipment does cause harmful interference to radio or television reception, which can be determined by turning the equipment off and on, the user is encouraged to try to correct the interference by one or more of the following measures:

- Reorient or relocate the receiving antenna.
- Increase the separation between the equipment and receiver.
- Connect the equipment into an outlet on a circuit different from that to which the receiver is connected.

Consult the dealer or an experienced radio/TV technician for help.

7.2.5 RF-exposure Statement

The BlueMod+B20 contains a portable modular transmitter. The max. output power of 10mW is well below the FCC limit of $60\text{mW}/f(\text{GHZ}) = 60\text{mW}/2,4 = 25\text{mW}$. Therefore no restrictions apply for the use of the BlueMod+B20 close to the human body.

7.2.6 Labeling requirements for the End Product

Any End Product integrating the BlueMod+B20 must be labeled with at least the following information:

This device contains transmitter with FCC-ID: RFR-B2029 IC: 4957A-B2029

7.3 Bluetooth Qualification

The BlueMod+B20 is a qualified design according to the Bluetooth Qualification Program Reference Document (PRD) V2.0. The Qualified Design ID (QDID) is:

B011904 for the BT 2.0+ EDR product

B017116 for the BT 2.1+ EDR product

For further information about marking requirements of your product attention should be paid the Bluetooth Product Marking Guide at https://programs.bluetooth.org/Download/Marking_Guide_20060601.pdf

According to the Bluetooth SIG rules (Qualification Program Reference Document – PRD V2.1) you are required to perform the mandatory End Product Listing (EPL) for your product. For further information see www.Bluetooth.org or contact Stollmann.



Bluetooth SIG Qualification Design (QDL) Certificate

QDL Certificate: This certificate represents the Specifications declared by the Member as having passed the Bluetooth Qualification/Certification Process as specified within the Bluetooth Specifications and as required within the PRD 2.0.

Project Name: **BlueMod+B20/B29**

Certified



This Product Design has passed the Bluetooth Qualification Process!

QDID: B011904

Declared Specifications: Radio, Baseband Conformance, Link Manager, Logical Link Control and Adaption Protocol, Service Discovery Protocol, Generic Access Profile, RFCOMM, Serial Port Profile, Host Controller Interface

Member Company:	Requirements:	Project Dates:
Stollmann E+V GmbH Mendelssohnstr. 15d empty Hamburg, 22761	1. Testing 2. Documentation 3. Assessment 4. Declaration 5. Listing 6. Marking 7. Compliance to Auditing and Enforcement	Assessment Date: September/29/2006 Listing Date: September/29/2006
Approved By BQE: Nikolaus Wahl		

Figure 7.1 Qualification Design Certificate B011904

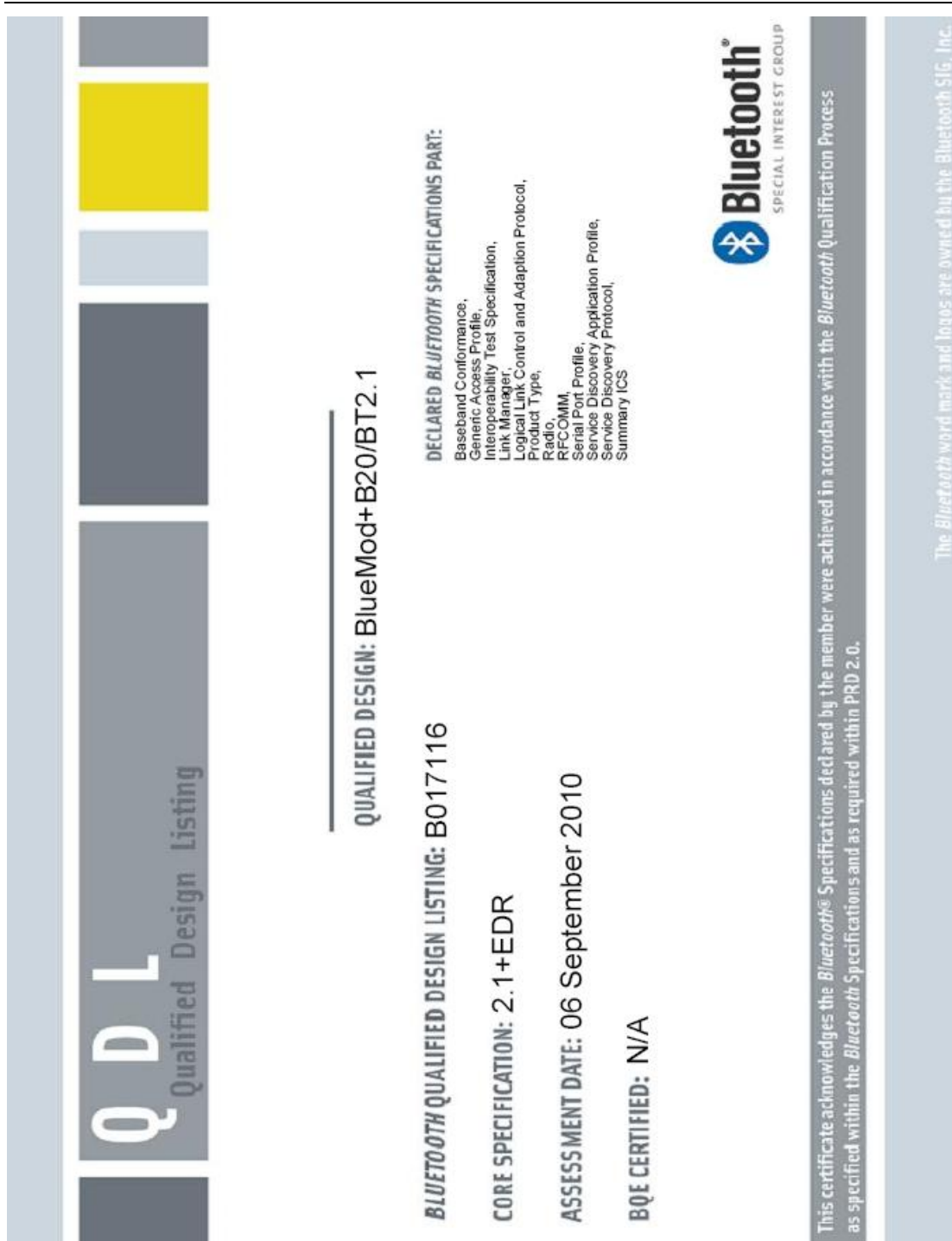

QDL
Qualified Design Listing

QUALIFIED DESIGN: BlueMod+B20/BT2.1

BLUETOOTH QUALIFIED DESIGN LISTING: B017116

CORE SPECIFICATION: 2.1+EDR

ASSESSMENT DATE: 06 September 2010

BQE CERTIFIED: N/A

DECLARED BLUETOOTH SPECIFICATIONS PART:
Baseband Conformance,
Generic Access Profile,
Interoperability Test Specification,
Link Manager,
Logical Link Control and Adaption Protocol,
Product Type,
Radio,
RFCOMM,
Serial Port Profile,
Service Discovery Application Profile,
Service Discovery Protocol,
Summary ICS



Bluetooth
SPECIAL INTEREST GROUP

This certificate acknowledges the Bluetooth[®] Specifications declared by the member were achieved in accordance with the Bluetooth Qualification Process as specified within the Bluetooth Specifications and as required within PRD 2.0.

The Bluetooth word mark and logos are owned by the Bluetooth SIG, Inc.

Figure 7.2 Qualification Design Certificate B017116

7.4 RoHS Declaration

Declaration of environmental compatibility for supplied products:

Hereby we declare to our best present knowledge based on declaration of our suppliers that this product do not contain by now the following substances which are banned by Directive 2002/95/EC (RoHS) or if contain a maximum concentration of 0,1% by weight in homogeneous materials for

- Lead and lead compounds
- Mercury and mercury compounds
- Chromium (VI)
- PBB (polybrominated biphenyl) category
- PBDE (polybrominated biphenyl ether) category
- And a maximum concentration of 0,01% by weight in homogeneous materials for
- Cadmium and cadmium compounds

8 Related Documents

- [1] CSR BlueCore4-External_Databook_BC417143B-db-001Pf.pdf
- [2] Stollmann: AppNote_B0601_Antenna_Design_V1_0.pdf
- [3] BlueMod+B2x AT Command Reference
- [4] BlueMod+B20\BT2.1 AT Command Reference

10 Ordering Information

BlueMod+B20 is available in the following variants:

Name	Antenna	Article No.	MOQ / units	Comments
BlueMod+B20/AI/I/SPP	Internal	54357	50	Serial Port Profile Firmware
BlueMod+B20/AI/I/SPP/FCC	Internal	53017	50	Serial Port Profile Firmware, labeled FCC compliant
BlueMod+B20/AI/I/HCI-UART	Internal	54358	50	HCI firmware
BlueMod+B20/AP/I/SPP	External	52741	5000	Serial Port Profile Firmware
BlueMod+B20/AI/I/HCI-USB	Internal	53018	50	HCI firmware, USB
BlueMod+B20/AP/L/HCI-USB	External	53062	50	HCI firmware, USB
BlueMod+B20/AI/BT2.1/SPP	Internal	53132	50	Bluetooth 2.1 compliant, Serial Port Profile Firmware

11 History

Version	Release Date	By	Change description
0.50	17.05.2006	GJ	Correction: RESET# is active LOW active LOW signal names end with # sign
0.60	23.05.2006	GJ	Correction: AIO pinning
0.70	30.08.2006	BG/JW	first combined version BlueMod+B20/Bluemod+B29
0.90	06.03.2007	FH/AA	B29 removed,
1.00	12.03.2007	JW	Enhanced 7.3 Bluetooth Qualification First non preliminary version
1.01	28.03.2007	JJ	Ergänzungen Cetecom, Foto updated
1.02	03.04.2007	AA/JW	Figure 4.1 and 6.4 corrected Added 7.1 Declaration of conformity and Startup time
1.03	03.04.2007	AA	Chapter 3.1: DC-Voltages, Chapter 3.2 : Power ON Reset
1.04	02.05.2007	JJ	Chapter 4.2.2 Application Specific Pin Description Usage Tables completed
1.06	27.06.2007	AA	First combined version BlueMod+B20/AI (internal antenna) and BlueMod+B20/AP (external antenna) Chapter 4 and 6: Drawings for BlueMod+B20/AI actualised, for BlueNod+B20/AP new
r02	15.08.2007	AA/BG FH BG FH/AA JW	New template Dimension corrected in chapter 1.1 Chapter 4: Figures Chapter 6.1: Figures Chapter 6.2: Figures Typos Grammar Minimum order quantities 3.8.2 removed and integrated in 3.8.3 and 3.8.4 (now 3.8.2 and 3.8.3) 3.9.1 moved to 3.9 Chapter « Safety Guidelines » removed Added last page Corrected Internal crystal oscillator (26 MHz) Formatting corrected in chapter 4 Note: It is highly recommended to make the SPI accessible in your design to ensure a future firmware upgrade for your mod- ule! Pin Description introduced /C and /I versions added HCI variants corrected all tables in chapter 4 Note: It is highly recommended to make the SPI accessible in your design to ensure a future firmware upgrade for your mod- ule! Pin Description

Hardware Reference

r03	13.12.2007	JW AA	added MOQ for BlueMod+B20/AI//SPP removed commercial variant, no longer available article number for BlueMod+B20/AI//HCI corrected 4.2 Pin Description Pinning for AP Version added 5.4 Digital I/O including RESET# Input Current 5.8 RF performance Output Power, BER and C/I corrected; 6.6 Antenna Issues Antenna Issues new 6.7 Safety Guidelines new
r04	04.07.2008	HB	1 Introduction: download link added 3.3.1 3-wire Serial Interface: description added 3.9 Serial Peripheral Interface: hint for layout 4.2.2.1 SPP Pin Configuration DCE Mode: USB pin description changed 4.2.2.2 SPP Pin Configuration DTE Mode: USB pin description changed 5.7.2 SPP Configuration: revised power values 5.9 Power-up time: changed time value 9 Packing: chapter added 7.2.5 RF-exposure Statement revised 7.3 Bluetooth Qualification: added EPL statement
r05	11.03.2009	JW	added ordering info for BlueMod+B20/AI//SPP/FCC added notes to chapter 7.2 FCC Compliance and FCC grant
r06	16.12.2010	HB	Chapter 5.7.2: added current consumption value for 230400 baud Chapter 10: revised ordering information Added variant BlueMod+B20/BT2.1/AI/SPP Added product variant BlueMod+B20/AP/L in the complete document Introduction: changed download link Added chapter 3.3.2: Baudrate tolerance

BlueMod+B20/AI
BlueMod+B20/AP
BlueMod+B20/AP/L
Hardware Reference



Stollmann Entwicklungs- und Vertriebs-GmbH
Mendelssohnstraße 15 D
22761 Hamburg
Germany

Phone: +49 (0)40 890 88-0
Fax: +49 (0)40 890 88-444
E-mail: info@stollmann.de
www.stollmann.de